

Presentation

The Hot Standby option, compatible with Concept and ProWORX software, provides Quantum series CPUs with the high dependability that security-critical applications demand. Central to the system is a standby controller—a second Quantum system configured identically with the primary control system with special hot standby modules mounted in both backplanes. The standby controller uses a high-speed fiber optic link to constantly maintain the current system status of the primary controller. In the event of an unexpected failure in the primary controller, system control automatically switches over to the standby controller. Critical processes running on a remote I/O network remain intact, unaffected by controller hardware failures. The result is higher productivity with reduced down-time.

At the beginning of every primary controller scan, the current register and I/O state table is transferred to the standby controller across a secure, high-speed fiber optic link. If switchover is triggered, the standby controller takes control of the system with up-to-date I/O and register status for a bumpless, controlled transfer with minimal process impact. At switchover, the standby controller becomes the primary controller and, when the downed controller is restored to good health, it becomes the standby.

Most applications demand that identical logic programs reside in the two controllers. User logic comparisons between the two controllers are performed at startup and during runtime. By default, the standby controller is taken offline if a logic mismatch is detected. It is possible to allow logic mismatches to coexist for high availability during maintenance periods. If minor process changes are required. The user can make them without disturbing standby operations.

In the event that the standby controller does not have the application program, it can be copied from the primary controller. Copying the program is a simple two-step procedure that uses the keyswitch and update button on the front of the standby controller. This task can be accomplished by a maintenance person without the use of a programming panel.

For ease of ordering and installation, Schneider offers three preconfigured kits for hot standby applications.

- The **140 CHS 210 00** kit includes all the products necessary to add the hot standby to an existing system.
- The other two kits, **140 CHS 410 10** and **140 CHS 410 20**, contain hot standby, backplanes, power supplies, and Quantum controllers.

Description

The Hot Standby module **140 CHS 110 00** comprises on the front panel:

- 1 A model number and color code.
- 2 A LED array.
 - Ready (green) - module has completed start-up diagnostic ,blinks to indicate transmission errors.
 - Com Act (green) - communicating with I/O bus, blinks to indicate transmission errors).
 - Primary (green) - module controls the process.
 - Com Err (red) - indicates transmission errors, or connection interrupted.
 - Standby (amber) - module in standby mode; blinks during the update process.
- 3 A removable, hinged door and customer identification label.
- 4 A selector switches.
- 5 A micro switch.
- 6 An update pushbutton.
- 7 A fiber optic transmit cable connector.
- 8 A fiber optic receive cable connector.



Modicon Quantum automation platform

Hot Standby modules Concept - ProWORX 32

Hot standby cable topologies

A hot standby system controls the I/O drops on a remote I/O (RIO) network. The local backplanes for the primary and standby controllers each require a Quantum CPU, an RIO head-end adapter module and a **140 CHS 110 00** Hot Standby module. Critical I/O should never be used in the local backplane because it will not be switched over when primary control shifts from one controller to the other.

The two **140 CHS 110 00** Hot Standby modules are connected to each other by a special fiber optic cable. This link allows the standby controller to maintain the current system status of the primary controller. The two RIO head-end adapter modules connect to the RIO trunk cable via an **MA 0186 100** splitter.

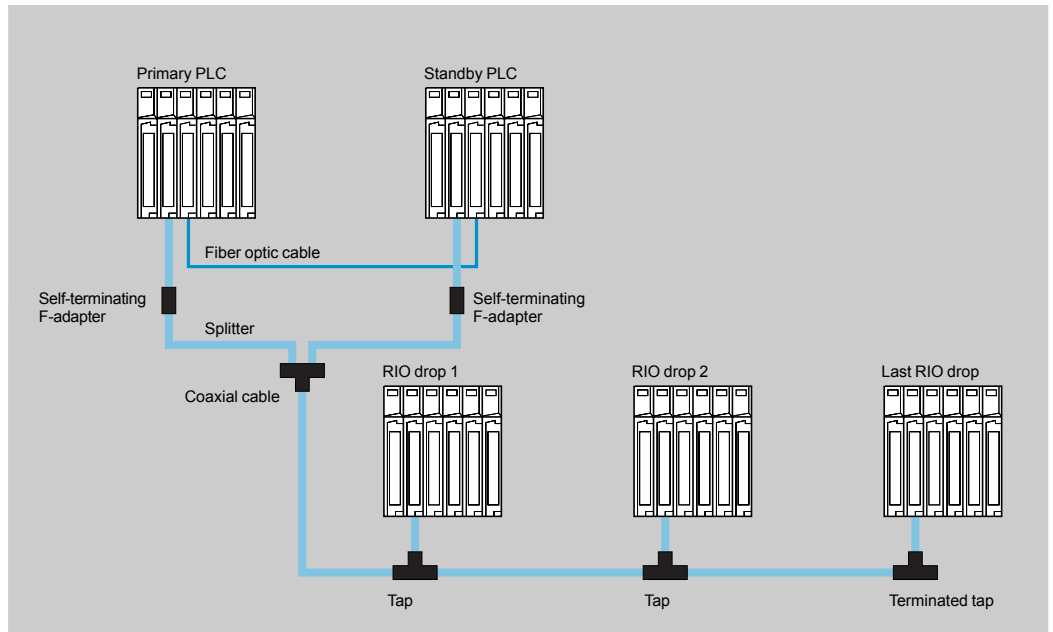

A hot standby system can also support a redundant RIO cable topology. The coaxial cables running from the two cable ports on the **140 CRP 932 00** head-end adapters in the two controllers are connected to the redundant RIO cable by separate **MA 0186 100** splitters.

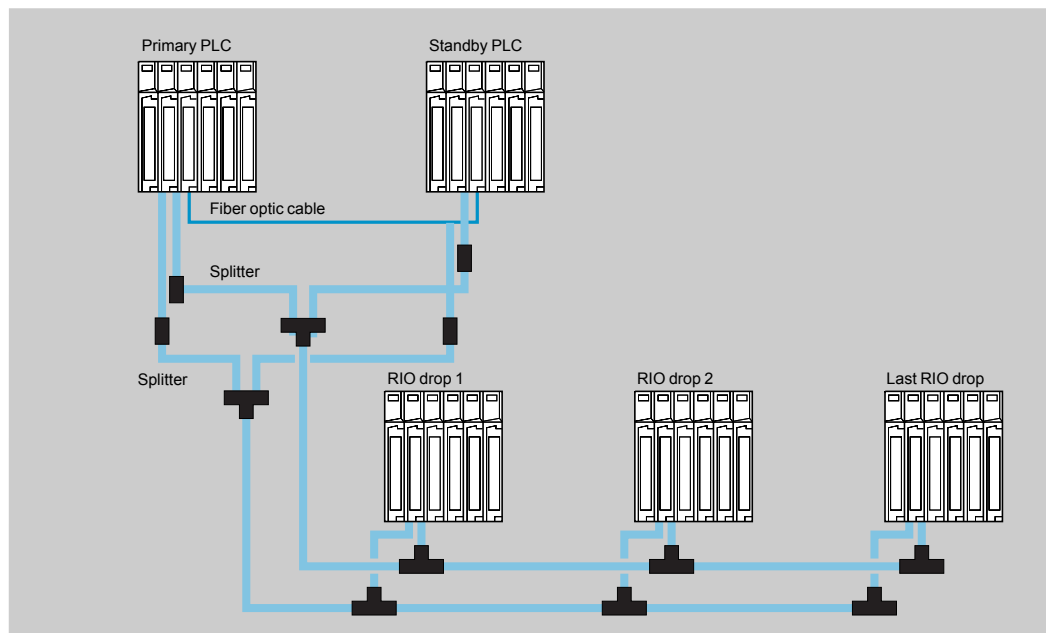

Characteristics		
Model		140 CHS 110 00
Common ports		2 connectors (transmit and receive) for fiber optic link
RFI immunity (per IEC 60801-3)	MHz	27...1000, 10 V/m
Bus current	mA	700 (typical)
Electrostatic discharge (per IEC 60801-2)	kV	8 air, 4 contact
Compatibility	Software	ProWORX NxT V2.0 or Concept Version \geq 2.0
	Quantum CPUs	All, 984 ladder logic; IEC, 140 CPU 434 12A/534 14B
Input/output type		Quantum, 800 Series, and Sy/Max (remote I/O only)
Fiber optic ports		1 transmit; 1 receipt
Programming software		ProWORX NxT V2.0 or Concept Version \geq 2.0
Quantum controllers		All, 984 ladder logic; IEC, 140 CPU 434 12A/534 14B
CHS loadable software requirements		Version \geq 2.0
Loadable function block performance		CHS blocks (included with le kit Hot Standby 140 CHS 210 00)
Switchover time	ms	13 to 48 for hot standby to assume control after primary fault detected
Scan impact communications	ms	3 + 6 per kB of configured state RAM
CHS communications rate	Mbit/s	10
Cables between Quantum systems	m	3, fiber optic
Current requirements	mA	700

Modicon Quantum automation platform

Hot Standby modules Concept - ProWORX 32

References			
Description	Components	Reference	Weight kg (lb)
Hot Standby module	–	140 CHS 110 00	1.06 (2.33)
Hot Standby kit for open configuration	2 CHS Hot Standby modules 1 fiber optic (3m) hot standby cable 1 CHS loadable software package 1 S908 terminator kit CHS installation manual	140 CHS 210 00	–
Hot Standby kit for Quantum CPU 140 113 02	2 140 CPU 113 02 Quantum CPUs, 2 140 CHS 110 00 Hot Standby processors 2 140 CRP 931 01 remote I/O processors 2 140 CPS 111 00 power supplies 2 140 XBP 006 00 backplanes 1 CHS loadable software package 1 fiber optic (3m) hot standby cable 1 S908 terminator kit CHS installation manual	140 CHS 410 10	–
Hot Standby kit for Quantum CPU 113 03	2 140 CPU 113 03 Quantum CPUs, 2 140 CHS 110 00 Hot Standby processors 2 140 CRP 931 01 remote I/O processors 2 140 CPS 111 00 power supplies 2 140 XBP 006 00 backplanes 1 CHS loadable software package 1 fiber optic (3m) hot standby cable 1 S908 terminator kit CHS installation manual	140 CHS 410 20	–
User documentation	Quantum Hot Standby System Planning and Installation Guide	840 USE 106 00	–

Associated modules			
Description	Topology	Reference	Weight kg
RIO head-end adapter module	Single cable	140 CRP 931 00	–
	Redundant cable	140 CRP 932 00	–

Accessories				
Description	Use/component	Length	Reference	Weight kg
Splitter	Tee for joining sections of coaxial cable coming from 2 central control unit modules (140 CRP 93● 00). Constitutes the start of the RIO I/O backbone.	–	MA 0186 100	–
Line impedance for coaxial cable RG-6/RG-11	Impedance for RIO coaxial cable. Used to maintain a suitable RIO line on disconnection of the cable coming from the central control unit (140 CRP 93● 00). Connection at both ends on female connector.	–	52 0411 000	–
Earthing terminal for coaxial cable RG-6/RG-11	Earthing terminal for RIO coaxial cable. Used to maintain earthing of the RIO line on disconnection of the cable coming from the central control unit (140 CRP 93● 00). Connection at both ends on female connector.	–	60 0545 000	–