

Modicon Quantum automation platform

Discrete I/O

Input module wiring diagrams

Input modules

140 DAI 340 00/140 DAI 440 00/140 DAI 740 00

140 DAI 353 00/140 DAI 453 00

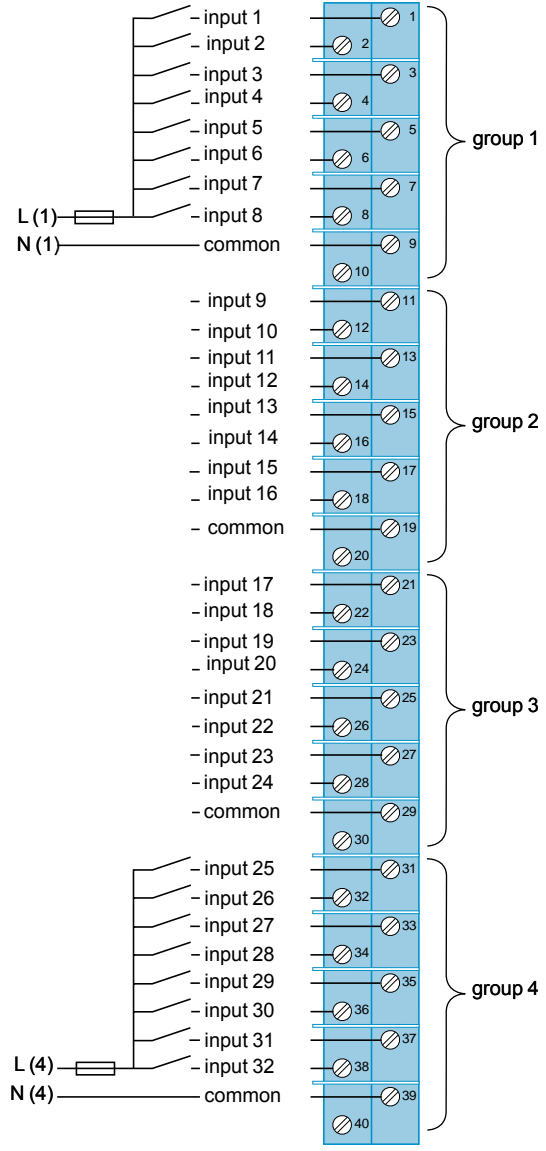
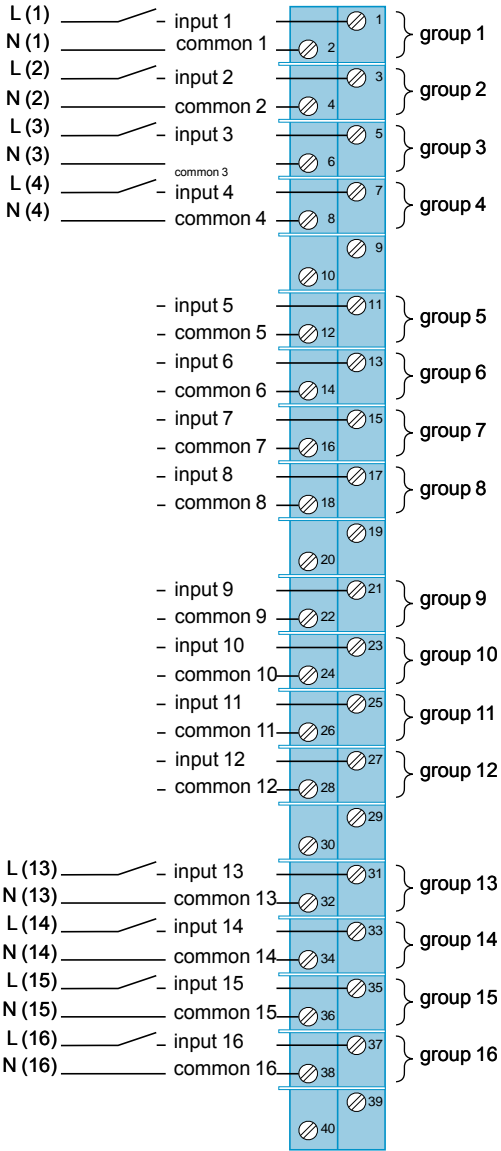

Input modules

140 DAI 540 00

140 DAI 543 00

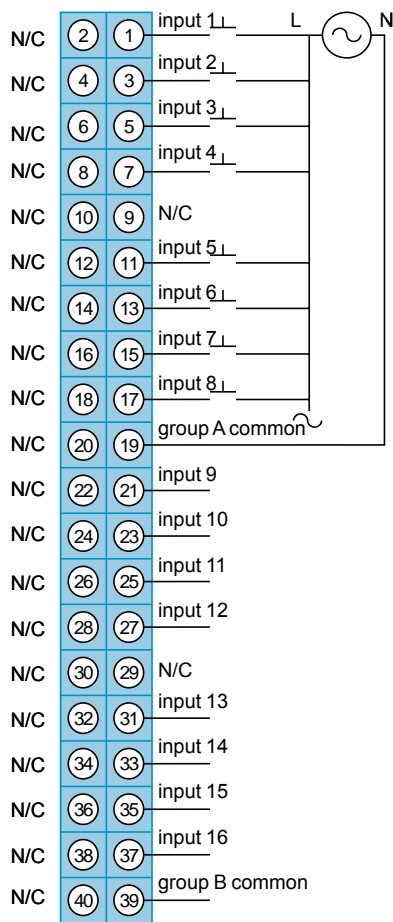
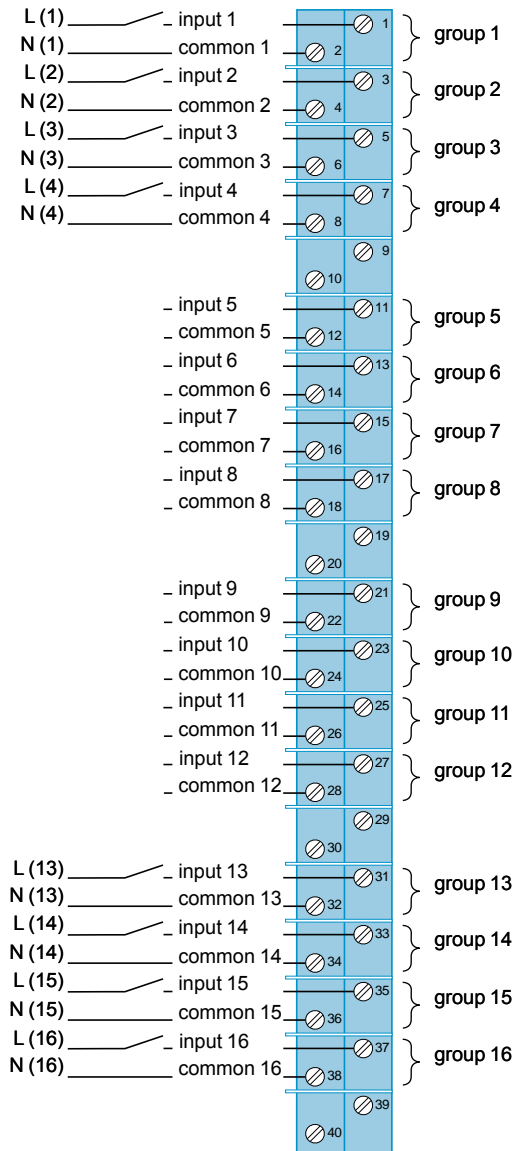

Modicon Quantum automation platform

Discrete I/O

Input module wiring diagrams

Input modules

140 DAI 553 00/140 DAI 753 00

140 DDI 153 10

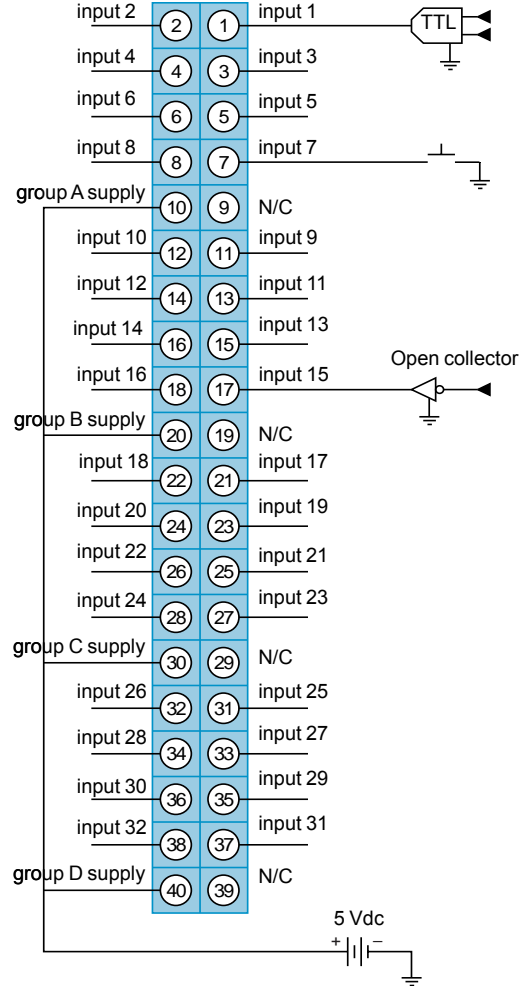
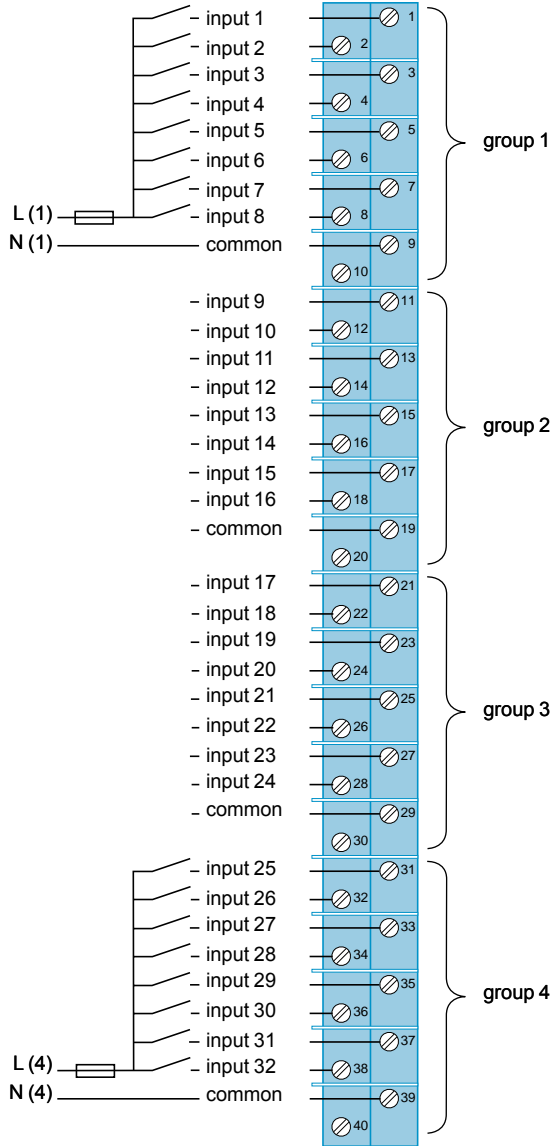

Modicon Quantum automation platform

Discrete I/O

Input module wiring diagrams

Input modules

140 DDI 353 00

140 DDI 353 10

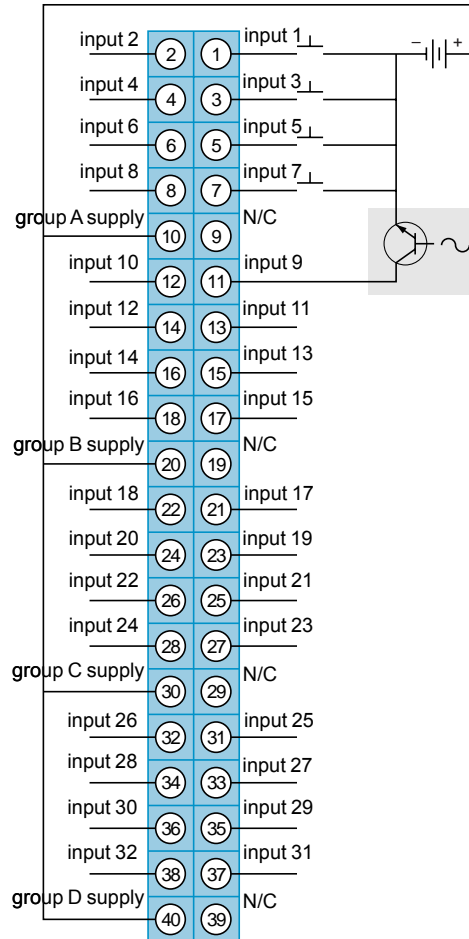
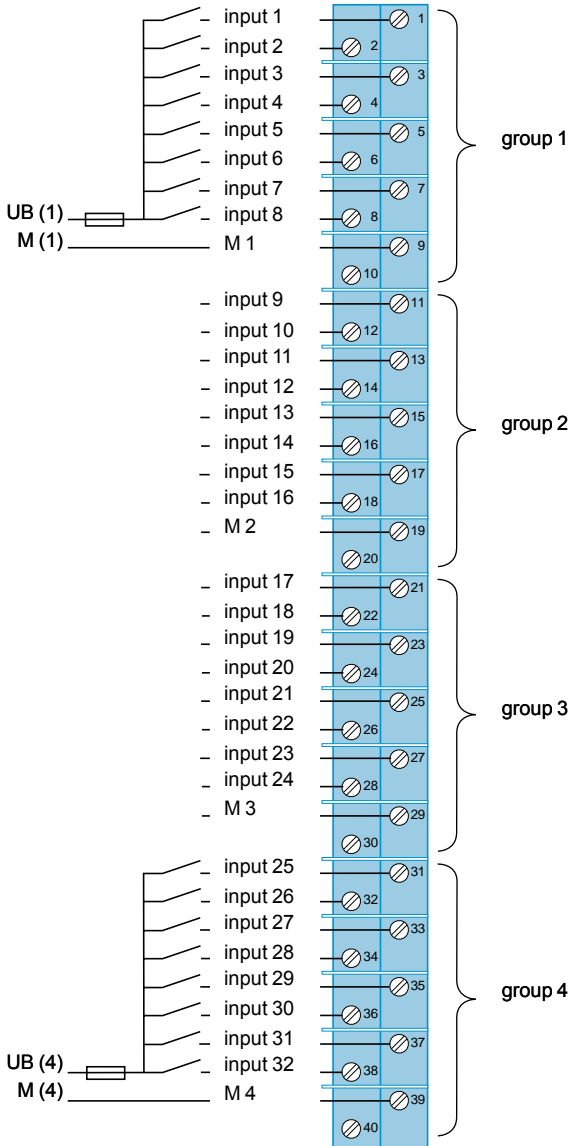

Modicon Quantum automation platform

Discrete I/O

Input module wiring diagrams

Input modules

140 DDI 364 00

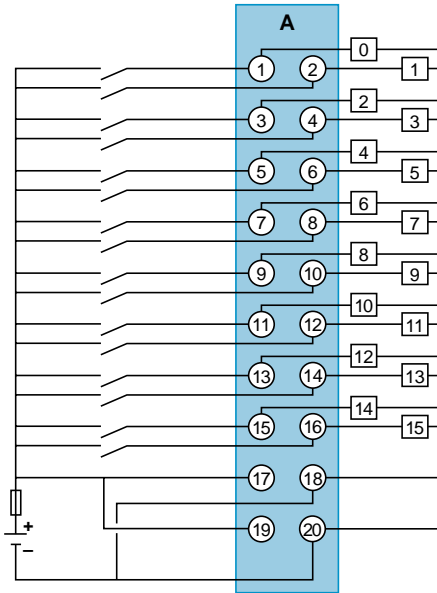

Note : connection requires Telefast terminal block.

140 DDI 673

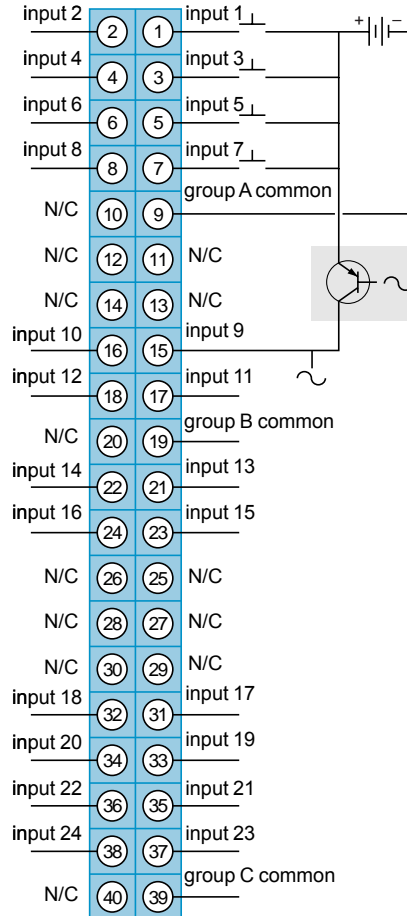

Modicon Quantum automation platform

Discrete I/O

Input module wiring diagrams

Input modules

140 DDI 841 00

140 DDI 853 00

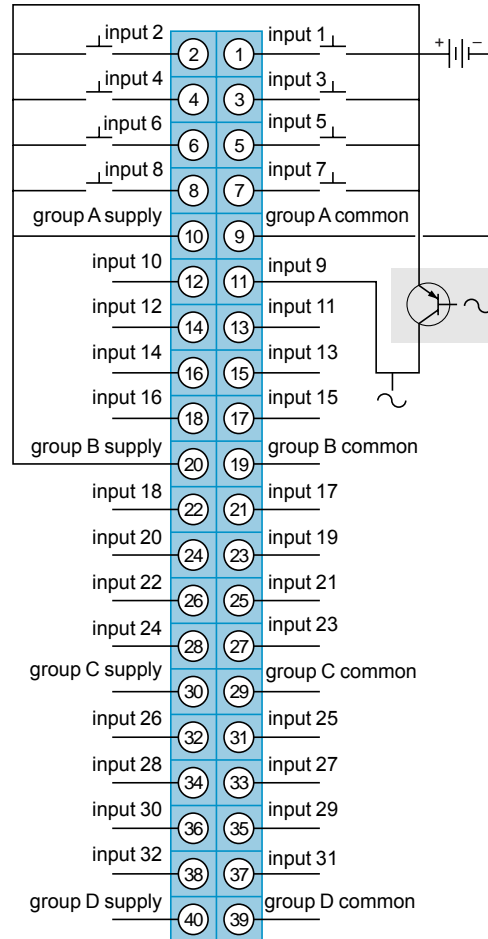
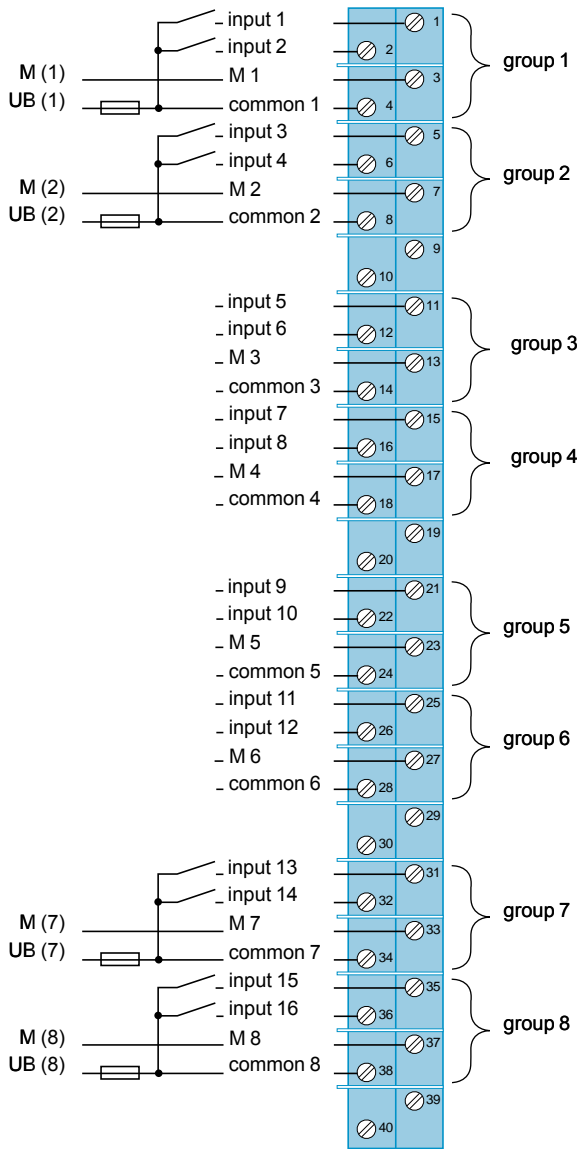

Modicon Quantum automation platform

Discrete I/O

Input module wiring diagrams

Input module
140 DSI 353 00

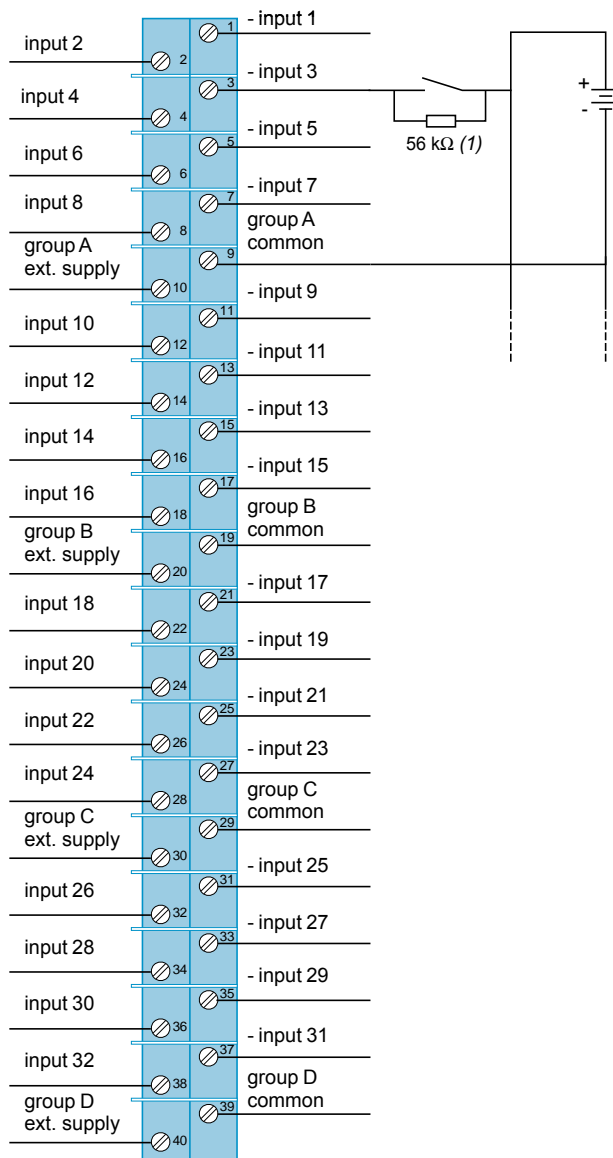

(1) Recommended resistor value for ≈ 24 V.

Modicon Quantum automation platform

Discrete I/O

Output module wiring diagrams

Output modules

140 DAO 840 00/140 DAO 840 10

140 DAO 842 10/140 DAO 842 20

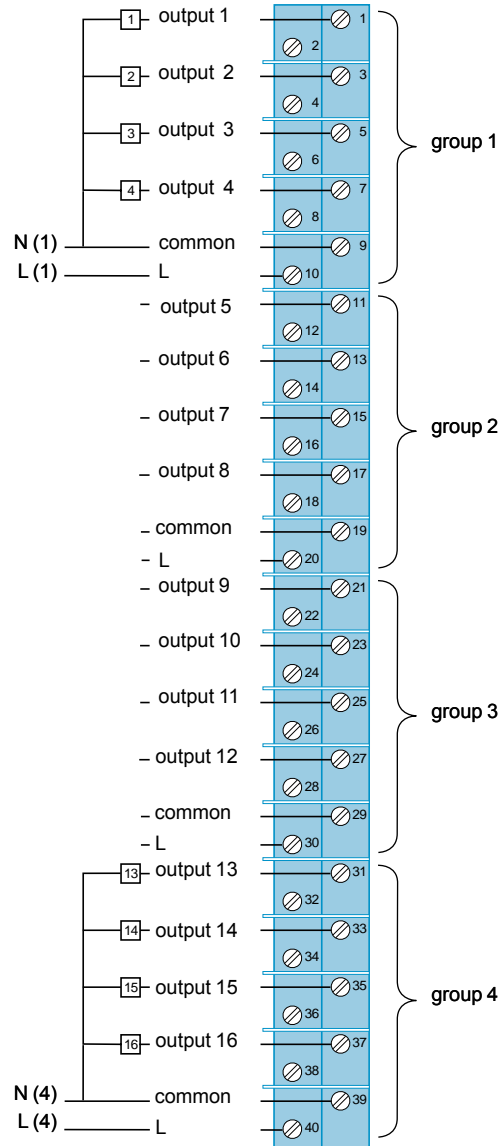
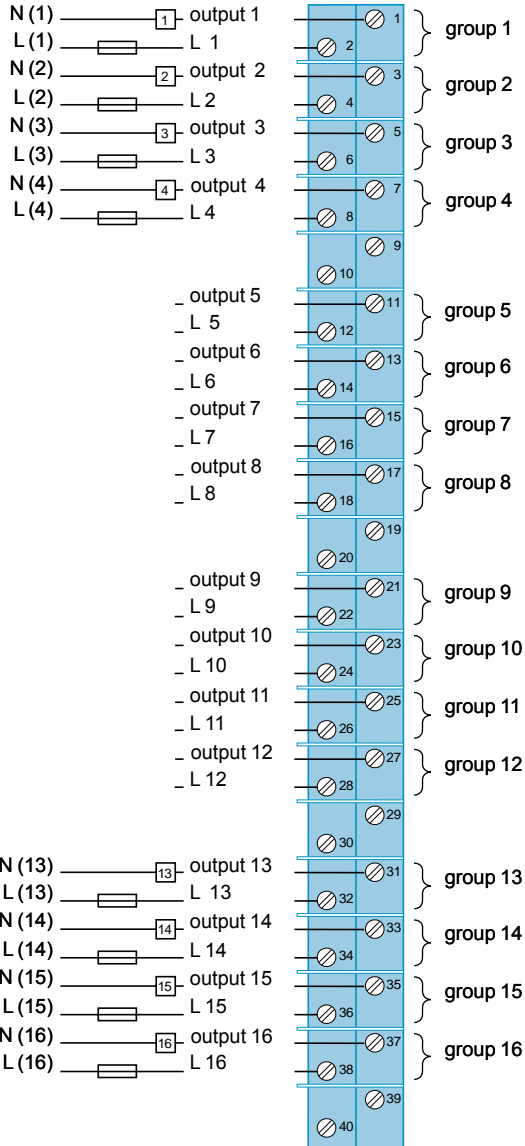

Output modules

140 DAO 853 00

140 DDO 353 00/140 DDO 153 10/140 DDO 353 10

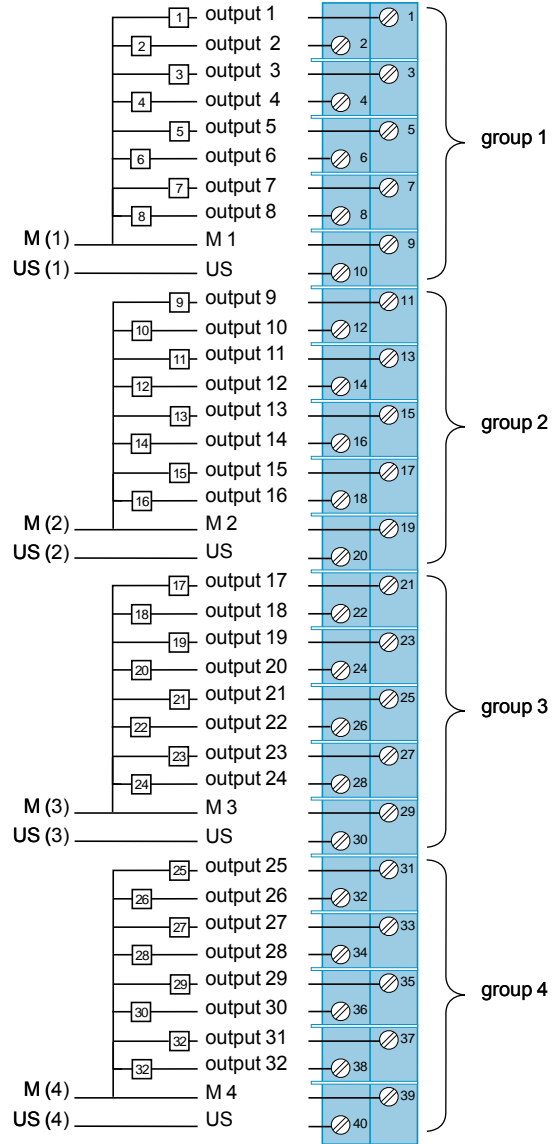
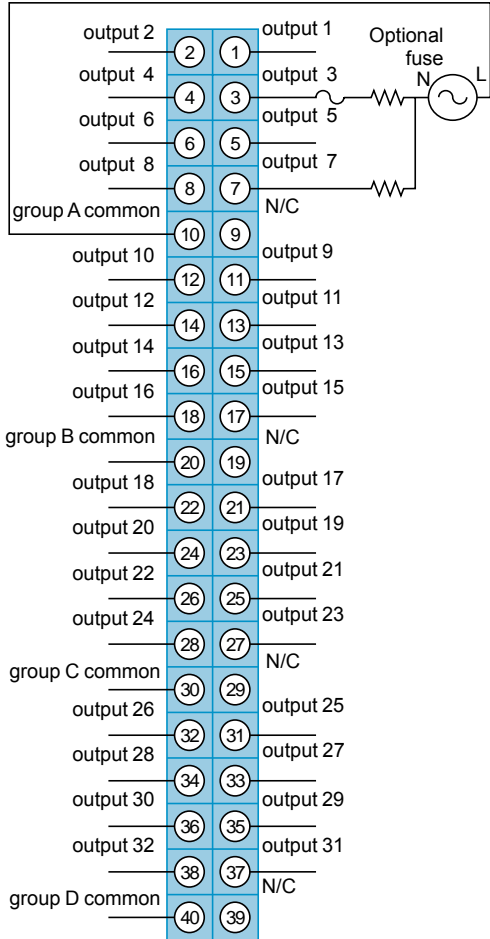

Output modules

140 DDO 353 01

140 DDO 364 00

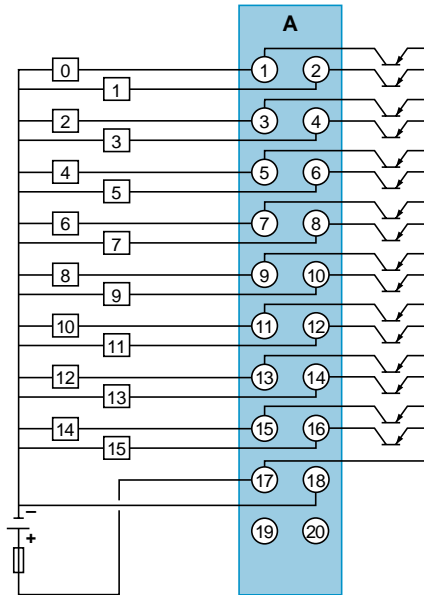
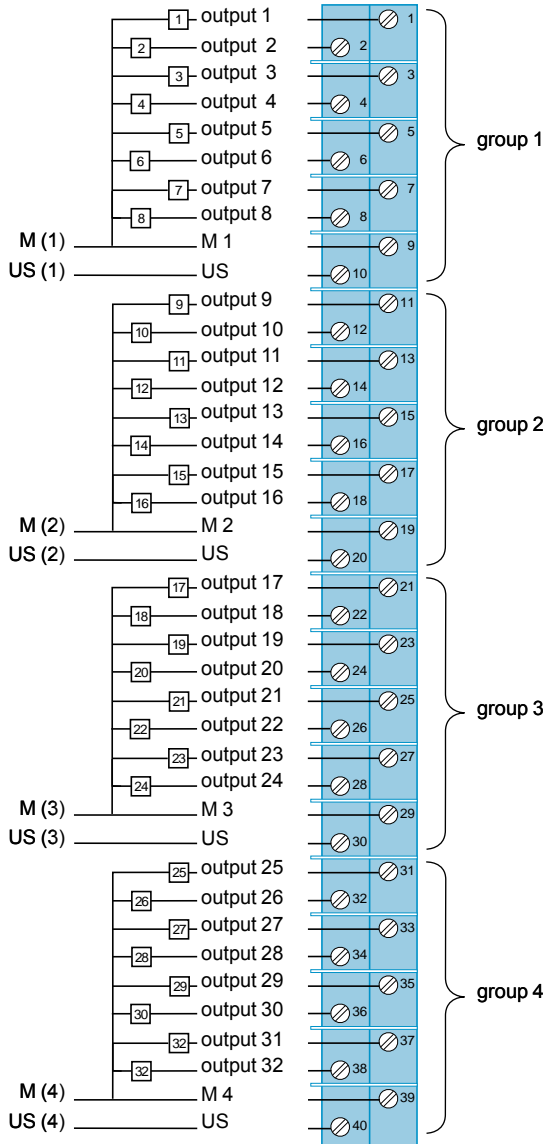

Note : connection requires Telefast terminal block.

Modicon Quantum automation platform

Discrete I/O

Output module wiring diagrams

Output module

140 DDO 885 00

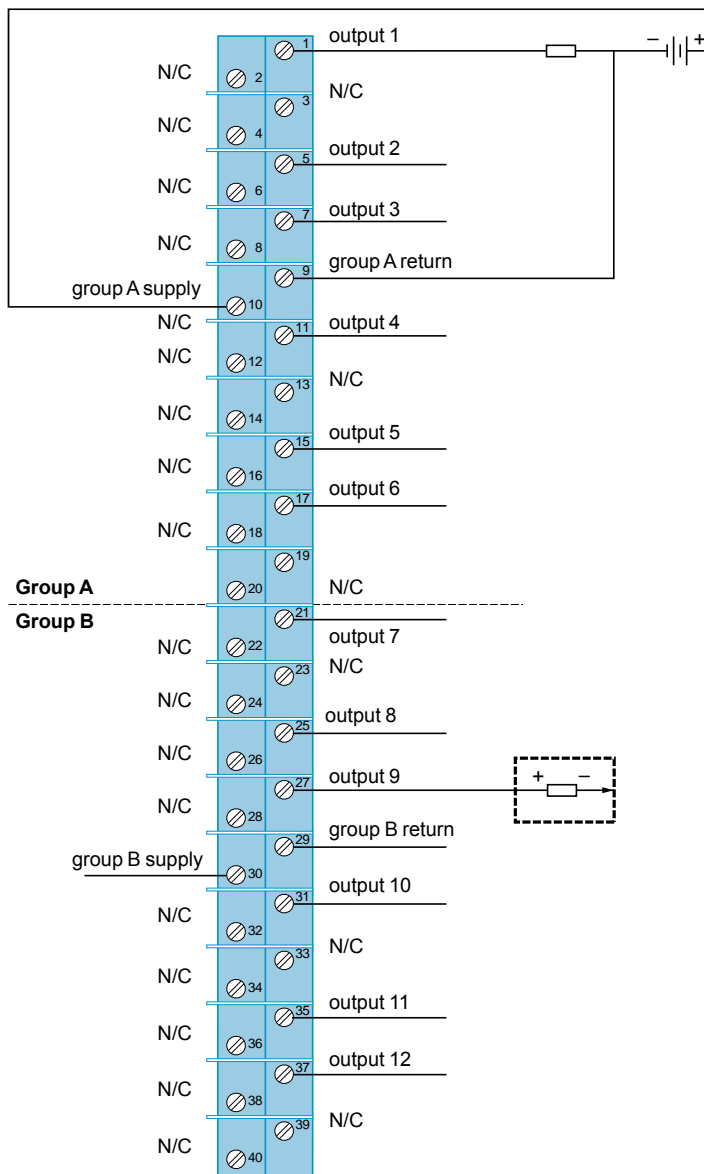

Modicon Quantum automation platform

Discrete I/O

Output module wiring diagrams

Output modules
140 DDO 843 00

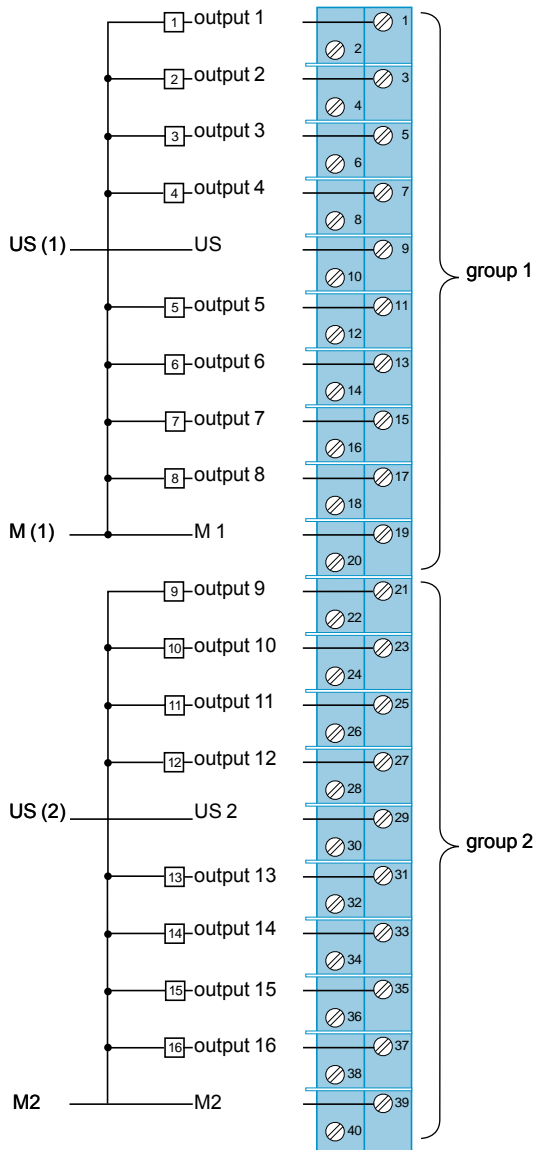

Modicon Quantum automation platform

Discrete I/O

Relay output module wiring diagrams

Relay output modules

140 DRA 840 00

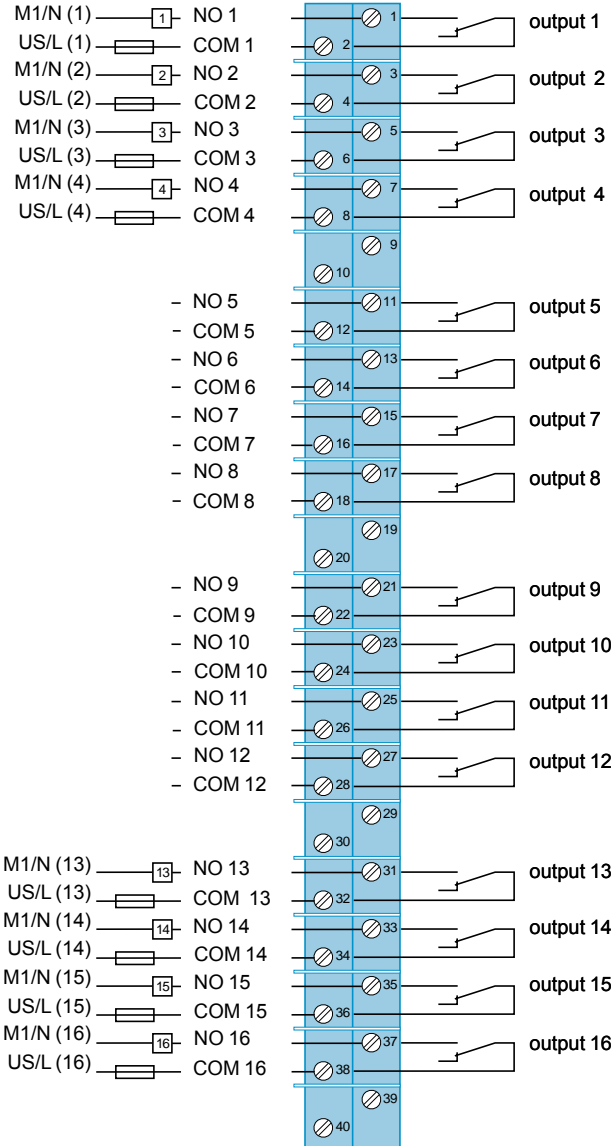

140 DRC 830 00

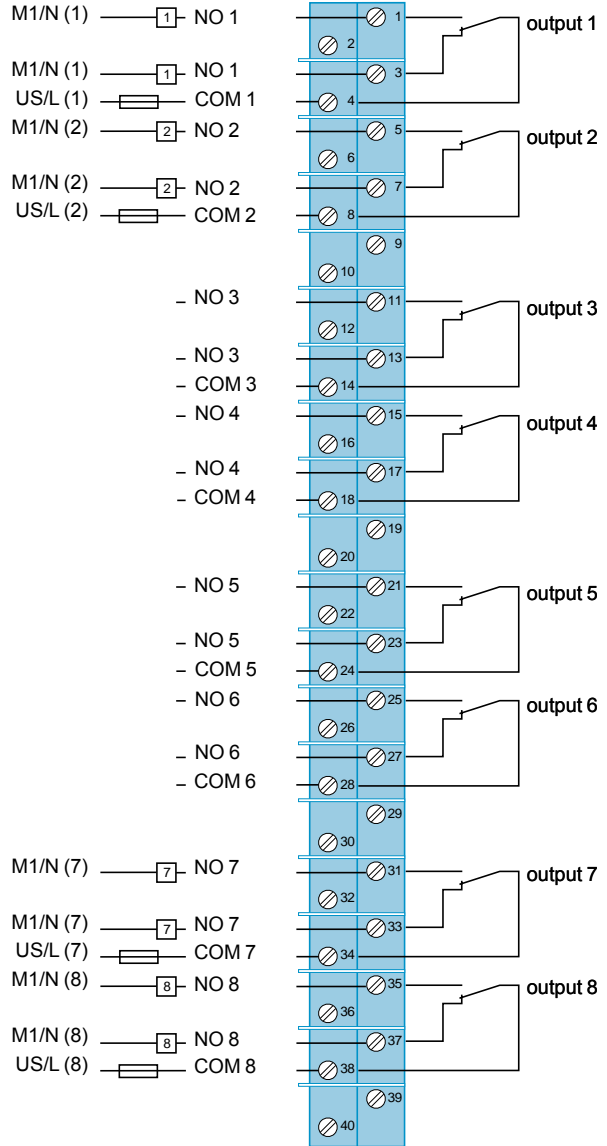

Modicon Quantum automation platform

Discrete I/O

Relay output module wiring diagrams

Relay output modules

140 DVO 853 00

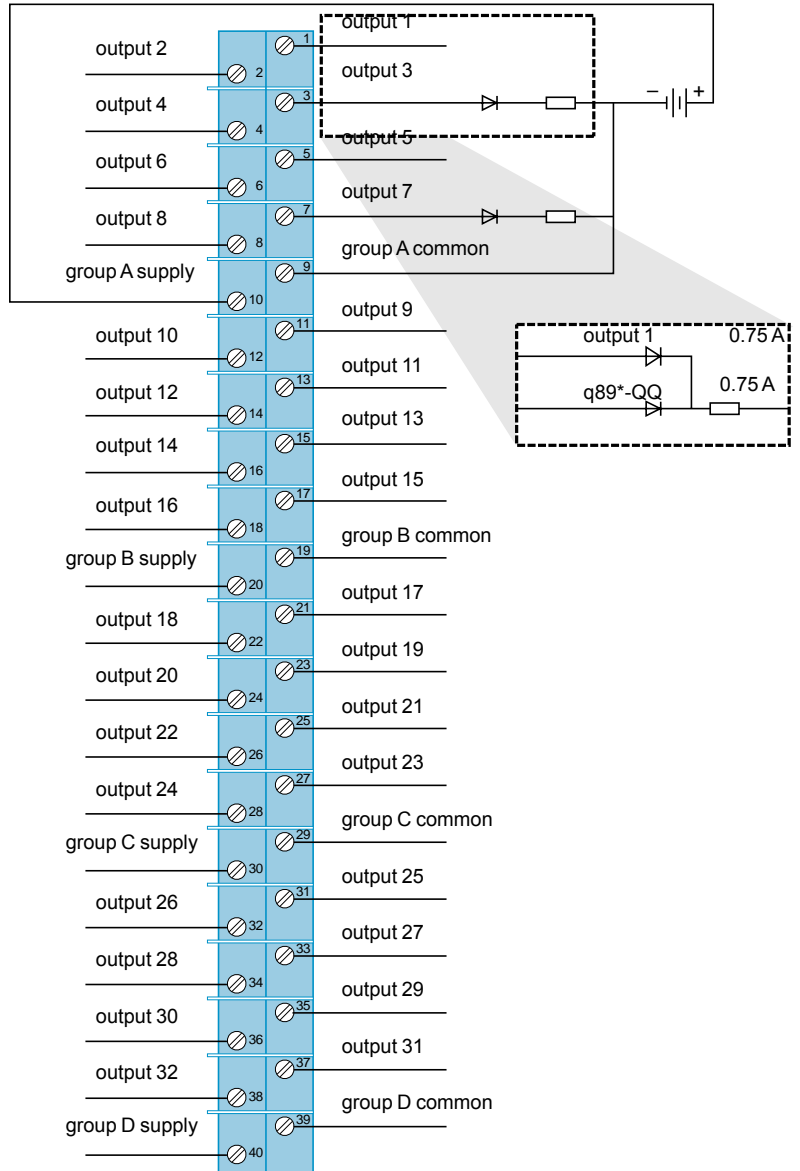

Nota : When driving a load from different points, a blocking diode is required for each point. These diode (shown above) will present false fault reporting when only one of the points is commanded ON.

Combo modules

140 DAM 590 00

140 DDM 390 00

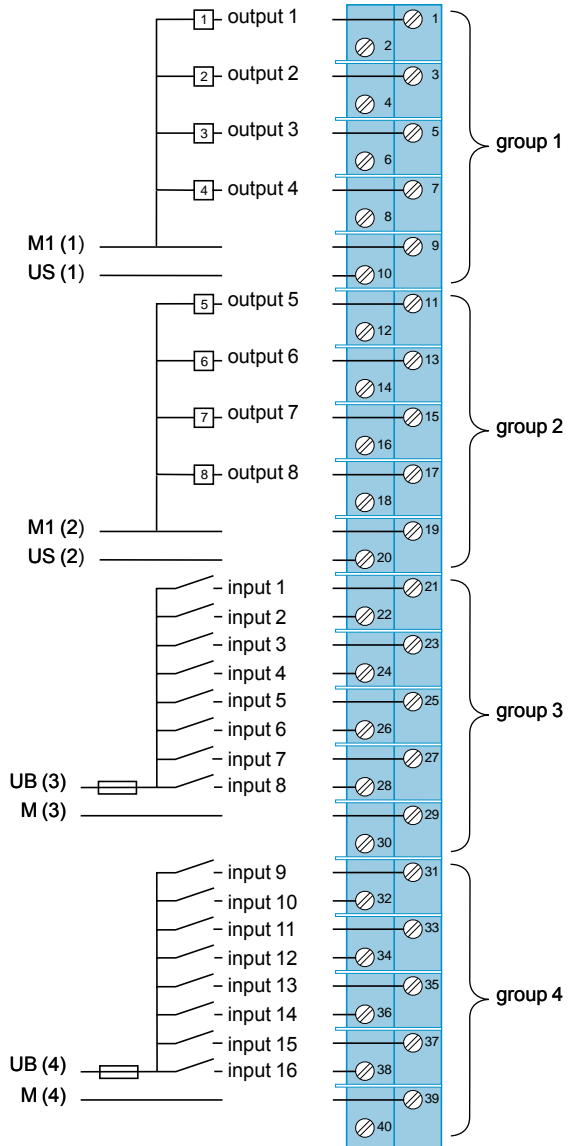
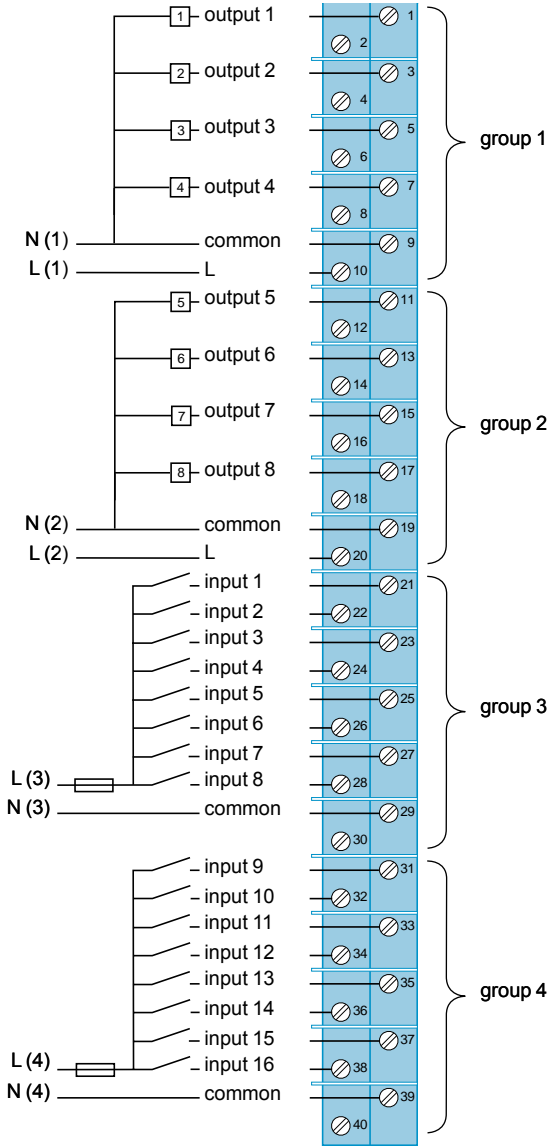

Modicon Quantum automation platform

Discrete I/O

Combo module wiring diagrams

Combo module
140 DDM 690 00

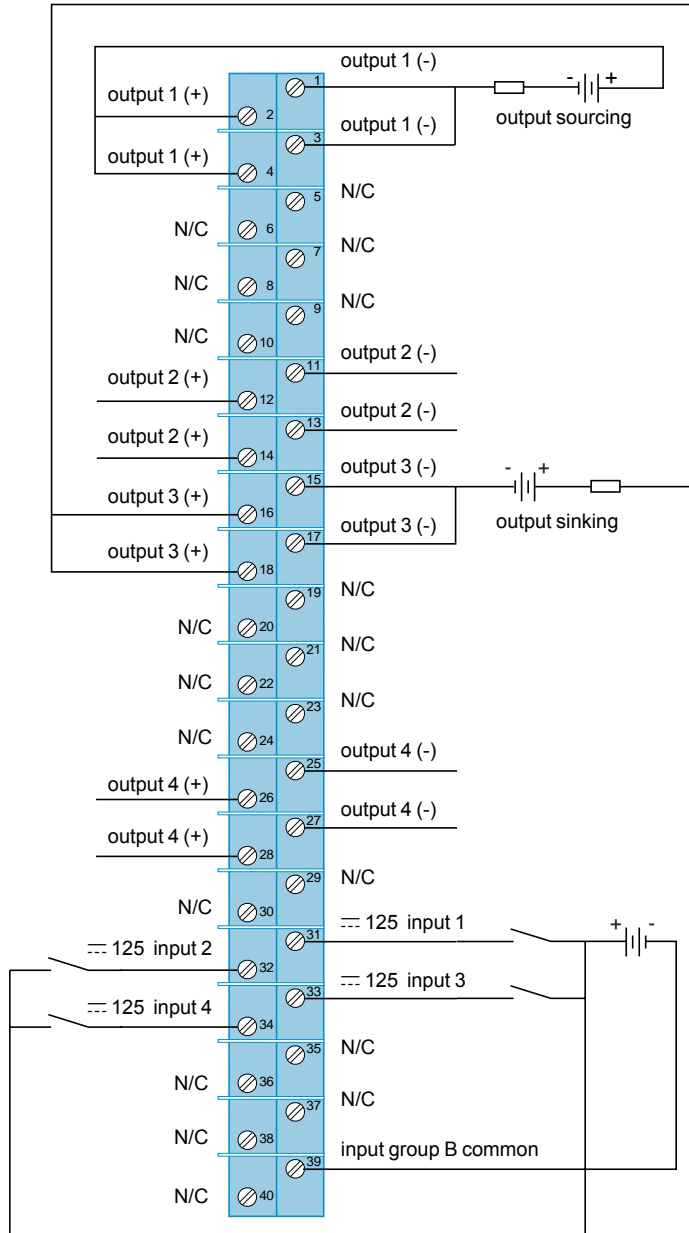

Caution:

The output points are not protected against reverse polarity. Reverse polarity will turn an output point ON.

Nota : Each output has terminals for multiple wire connections.
N/C = Not Connected.