

Modicon Quantum automation platform

Intrinsically safe I/O

Presentation

The Quantum Automation Platform supports a full range of intrinsically safe I/O modules designed to interface with a wide variety of field devices.

Intrinsic safety is a technique for ensuring that electrical energy supplied to circuits in a hazardous area is too low to ignite volatile gases either by spark or by thermal means. Intrinsically safe circuits use energy-limiting devices, known as intrinsically safe barriers, to prevent excess electrical energy from being applied to electrical equipment located in the hazardous area. These galvanically isolated barriers prevent the module from releasing sufficient energy to ignite volatile gases or vapors in the hazardous area.

Galvanic isolation, in the form of opto-isolators and DC/DC converters, is provided between the field side output circuitry and the Quantum bus circuitry. The DC/DC converters provide intrinsically safe power to field devices located in hazardous areas. No external field power is required where these modules are installed.

I/O intrinsically safe modules are designed to fit into a standard Quantum backplane. They can be mounted in any slot position in any slot size (3...16 slots) Quantum 140 XBP 0...00 backplane.

I/O connectors

Each intrinsically safe I/O module requires an I/O connector (140 XTS 332 00). The connector's field wiring terminal strip is color-coded blue to identify it as an intrinsically safe connector. The terminal strip is keyed to prevent the wrong connector from being applied to the module.

Wiring considerations

Intrinsically safe wiring between the intrinsically safe I/O modules and the field devices located in the hazardous area must be separated from all other wiring. This can be accomplished by any one of the following methods:

- Separate blue wire ducts, raceways, or conduits
- Grounded metal or insulated partitions between the intrinsically safe and non-intrinsically safe wiring
- A separation of two inches (50 mm) of air space between the intrinsically safe and non-intrinsically safe wiring. With this method, intrinsically safe and non-intrinsically safe wires must be tied in separate bundles to maintain the required separation.

Description

The 140 AII/AIO/DII/DIO 330 00 intrinsically safe modules comprise in front panel:

- 1 A model number and color code.
- 2 A LED indicator panel.
- 3 A removable, hinged door and customer identification label.
- 4 Terminal block, 40-pole. (To be ordered separately).

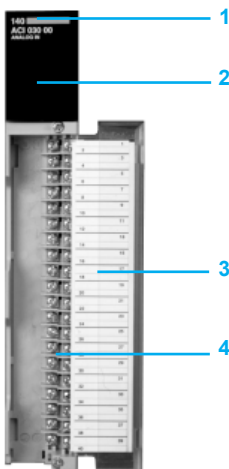

RTD/resistance and thermocouple/millivolt Input module					
Model		140 All 330 00 (RTD)	140 All 330 00 (Thermocouple)		
Numbers of channels		8			
LEDs		Active-1 (Green) F-1 (Red) 1 ... 8 (Red) - Indicated channel is out of range (includes broken wire & short circuit conditions)			
RTD types (configurable)	Platinum (American & European)	PT 100, PT 200, PT 500, PT 1000	°C	- 200 to + 850	–
	Nickel	N 100, N 200, N 500, N 1000	°C	- 60 to + 180	–
Ranges TC (1)	J		°C	–	- 210 ... + 760
	K		°C	–	- 270 ... + 1370
	E		°C	–	- 270 ... + 1000
	T		°C	–	- 270 ... + 400
	S		°C	–	- 50 ... + 1665
	R		°C	–	- 50 ... + 1665
	B		°C	–	- 130 ... + 1820
	Millivolt		mV	–	- 100 ... + 100 (2) - 25 ... + 25
Measurement current	PT 100, PT 200, N 100, N 200		mA	2.5	–
	PT 500, PT 1000, N 500, N 1000		mA	0.5	–
TC circuit resistance/max source resistance		Ω	–	–	200 max. for rated accuracy
Input impedance		MΩ	> 10	–	> 1
Input filter			–	–	Single low pass @ nominal 20 Hz. Plus notch filter at 50/60 Hz
Normal noise rejection		dB	> 100 @ 50/60 Hz	–	120 dB min. @ 50 or 60 Hz
Cold junction compensation (CJC)			–	–	Internal CJC operates 0 ... 60° C (errors are included in the accuracy specification). The connector door must be closed. Remote CJC can be implemented by connecting the TC (which monitors the external junction block temperature) to channel 1. Types J, K, and T are recommended for best accuracy.
Linearity			± 0.003% of full scale (0 to 60° C)	–	–
Resolution	RTD			12 bits + sign (0.1° C)	–
	TC			–	Choice of : 1° C (default), 0.1° C, 1 ° F, 0.1° F
	Millivolt			–	± 100 mV range, 3.05 mV (16 bits) ± 25 mV range, 0.76 mV (16 bits)

(1) All TC ranges have an open TC detect and upscale. This results in a reading 7FFFh or 32767 decimal when an open TC is detected
 (2) Open circuit detect can be disabled on these ranges.

RTD/resistance and thermocouple/millivolt Input module				
Model			140 All 330 00 (RTD)	140 All 330 00 (Thermocouple)
Absolute accuracy	RTD	°C	± 0.5 (25 °C) ± 0.9 (0 ... 60 °C)	–
	TC		–	Absolute accuracy includes all errors from the internal CJC, TC curvature, offset plus gain, for module temperature of 0 ... 60 °C. User supplied TC errors not included. For type J and K, add 1.5 °C inaccuracy for temperatures below - 100 °C. Type B cannot be used below 130 °C.
	Types J, K, E, T	°C	–	± 2 °C + 0.1% of reading
	Types S, R, B	°C	–	± 4 °C + 0.1% of reading
	Millivolt @ 25 °C	µV	–	± 20 mV + 0.1% of reading
	Accuray error @ 25 °C	Typical		± 0.05% of full scale
Maximum			± 0.1% of full scale	–
Accuracy drift w/temperature		µV/°C	–	0.15 mV/°C + 0.0015% of reading/°C maximum
Update Time (all channels)	3-wire	s	1.35 Sec	–
	2 or 4-wire	ms	750 m Sec	–
	TC/millivolt	s	–	1 Sec
Isolation	Channel-to-channel		–	
	Channel-to-bus		~ 1780 @ 47-63 or --- 2500 V for 1 minute	
Bus current required		mA	400	
Fault detection			Out of range or broken wire conditions	
External power			–	
Power dissipation		W	2	
Hot swap			Not allowed per intrinsic safty standards	
Fusing			Internal-not user accessible	
Programming software			Unity Pro, Concept version 2.2 or higher	
Agency approvals			CSA 22.2-142, FM Class1 Div.2, C€, cUL	

Current input and analog output modules			
Model		140 All 330 10	140 AIO 330 00
Number of channels		8	
Linear measuring range	mA	4...20 0...20 0...25	–
Absolute maximum input	mA	25 internally limited	–
Input impedance	Ω	100 ± 0.1% between V + and signal terminals	–
Resolution		4...20 mA, 0 to 4,095 counts 4...20 mA, 0 to 16,000 counts 0...20 mA, 0 to 20,000 counts 0...25 mA, 0 to 25,000 counts	15 bits within 4...20 mA
Loop resistance	Ω	–	500 maximum
Ranges	mA	–	4...20 (0 to 4095) 4...20 (0 to 16,000) 0...20 (0 to 20,000) 0...25 (0 to 25,000)
Available voltage		Terminals V+, V-, : = 14.5 V @ 25 mA Terminals V+, signal : = 13.6 V @ 20 mA	–
Accuracy error @ 25 °C	Typical	± 0.05% of full scale	± 0.2% of full scale
	Maximum	± 0.1% of full scale	–
Accuracy drift w/temperature	Typical	± 0.0025% of full scale / °C	40 PPM/ °C
	Maximum	± 0.005% of full scale / °C	70 PPM/ °C
Linearity		+ 0.003% of full scale	± 1 LSB
Common mode rejection		>100 dB @ 50/60 Hz	–
Input filter		Single pole low pass, -3 dB cutoff @ 15 Hz, ± 20%	–
Update time (for all channels)	ms	750	4
Settling time	ms	–	1 ms to ± 0.1% of the final value
Voltmeter monitor specifications	Range	V	0.250...1.250
	Scaling		$V_{out} \text{ (Volts)} = I_{loop} \text{ (mA)} \times 0.0625$
	Output impedance	Ω	62.5 typical
	Wire length	m	1 maximum
Isolation	Channel-to-channel		–
	Channel-to-bus		A 1780 V @ 47-63 Hz or = 2500 V for 1 minute
Bus current required	A	1.5	2.5
Fault detection		Broken wire (4...20 mA mode)	Open circuit in 4...20 mA range
External power		–	–
Power dissipation	W	7.5	12.5
Hot swap		Not allowed per intrinsic safety standards	
Fusing		Internal-not user accessible	
Programming software		Unity Pro, Concept, version 2.2 or higher, ProWORX	
Agency approvals		UL 508, CSA 22.2-142, FM Class1 Div.2, CC	

Modicon Quantum automation platform

Intrinsically safe I/O

Digital input and output module			
Model		140 DII 330 00	140 DIO 330 00
Number of points		8 input	8 output
Output voltage		V	–
Operating voltages & currents	No load voltage (between input + and input -)	$\overline{\text{V}}$	8
	Short circuit current	mA	8
	Switching point	mA	1.2 ... 2.1
	Switching hysteresis	mA	0.2
Switching frequency		Hz	100 maximum
Maximum load current	Each point	mA	–
	Per module	mA	–
	Off state leakage/point	mA	–
Response (resistive loads)	Off-on	ms	1
	On-off	ms	1
	Output protection (internal)		–
Internal resistance		K Ω	2.5
Input protection		Resistor limited	
Isolation	Channel-to-channel	–	
	Channel-to-bus	\sim 1780 V, 47-63 Hz or $\overline{\text{V}}$ 2500 V for 1 minute	
Bus current required		A	0.4
Fault detection		Resistor limited	
External power		–	
Power dissipation		W	2
Hot swap		Not allowed per intrinsic safety standards	
Fusing		Internal-not user accessible	
Programming software		Unity Pro, Concept, version 2.2 or higher, ProWORX	
Agency approvals		UL 508, CSA 22.2-142, cUL, C \AA	

Modicon Quantum automation platform

Intrinsically safe I/O

Intrinsically safe input modules

Description/resolution	Range	Reference	Weight kg (lb)
8 channels, up to 25,000 counts (4096...2500 points)	4 ... 20 mA, 0 ... 20 mA, 0 ... 25 mA	140 AII 330 10	0.300 (0.66)
8 channels, 12-bits plus sign, RTD	Ni or PT 100, 200, 500, 1000	140 AII 330 00	0.300 (0.66)
8 channels, 12-bits plus sign, thermocouple	Types J, K, E, T, S, R, B and	mV 140 AII 330 00	0.300 (0.66)
8 channels	1.2 mA ... 2.1 mA switch pt. current	140 DII 330 00	0.300 (0.66)

Intrinsically safe output modules

Description/resolution	Range	Reference	Weight kg (lb)
8 analog channels, 15-bit	4 ... 20 mA, 0 ... 20 mA, 0 ... 25 mA	140 AIO 330 00	0.300 (0.66)
8 I/O DIO, 12-bit	± 5 V, ± 10 V 0 ... 5 V, or 0 ... 10 V	140 DIO 330 00	0.450 (0.99)

Accessories

Description	Reference	Weight kg (lb)
Connector 40-points; blue color (IP20 rated)	140 XTS 332 00	0.150 (0.33)
User Documentation (contained in Quantum Hardware Reference Guide)	840 USE 100 00	–

RTD/resistance input module wiring diagram

140 AII 330 00

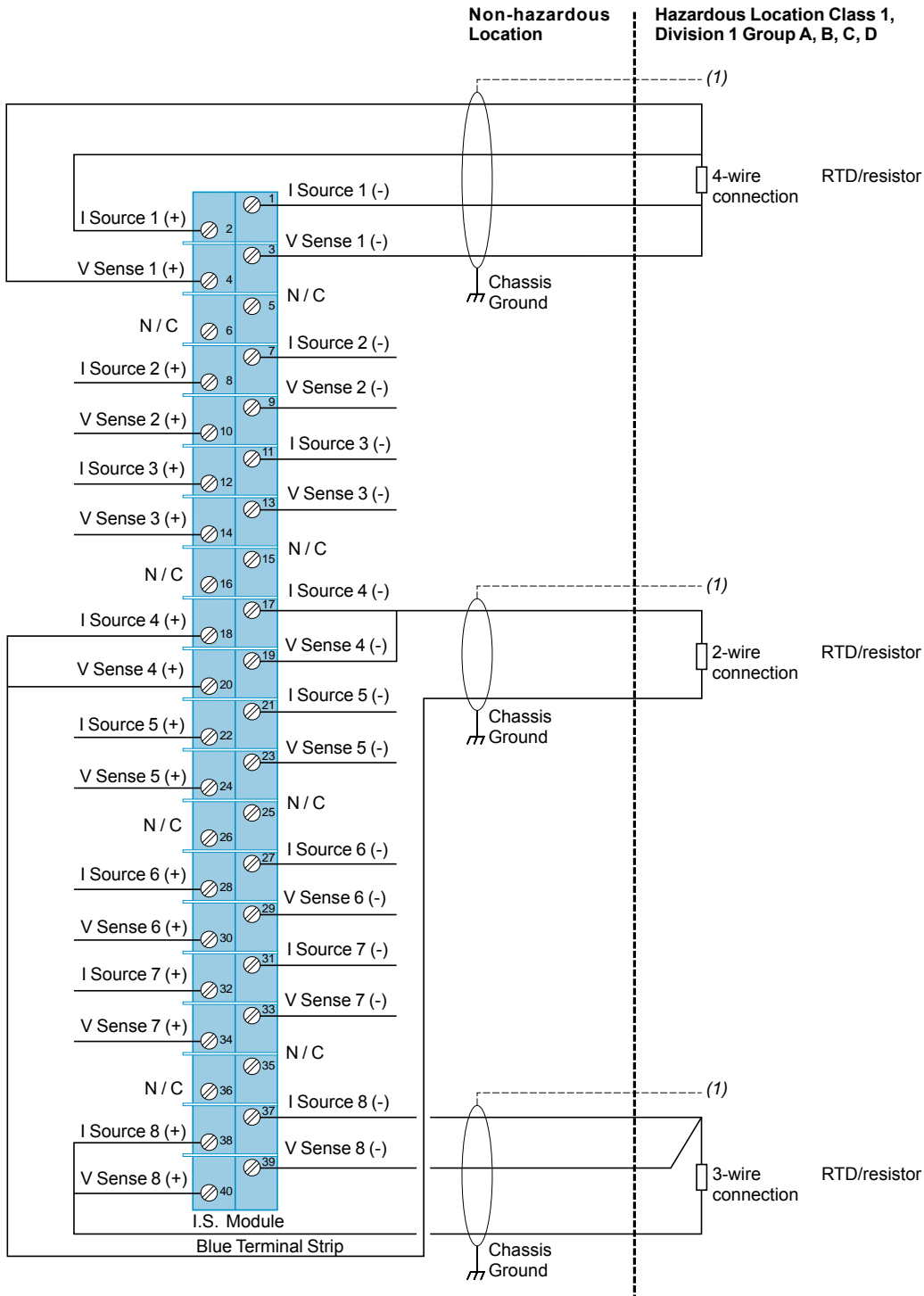

(1) Only shielded twisted pair cables should be used for connections. Shields should be left open at the field end and connected to chassis ground at the ground screws on the backplane.

RTD/resistance input module wiring diagram

140 All 330 00

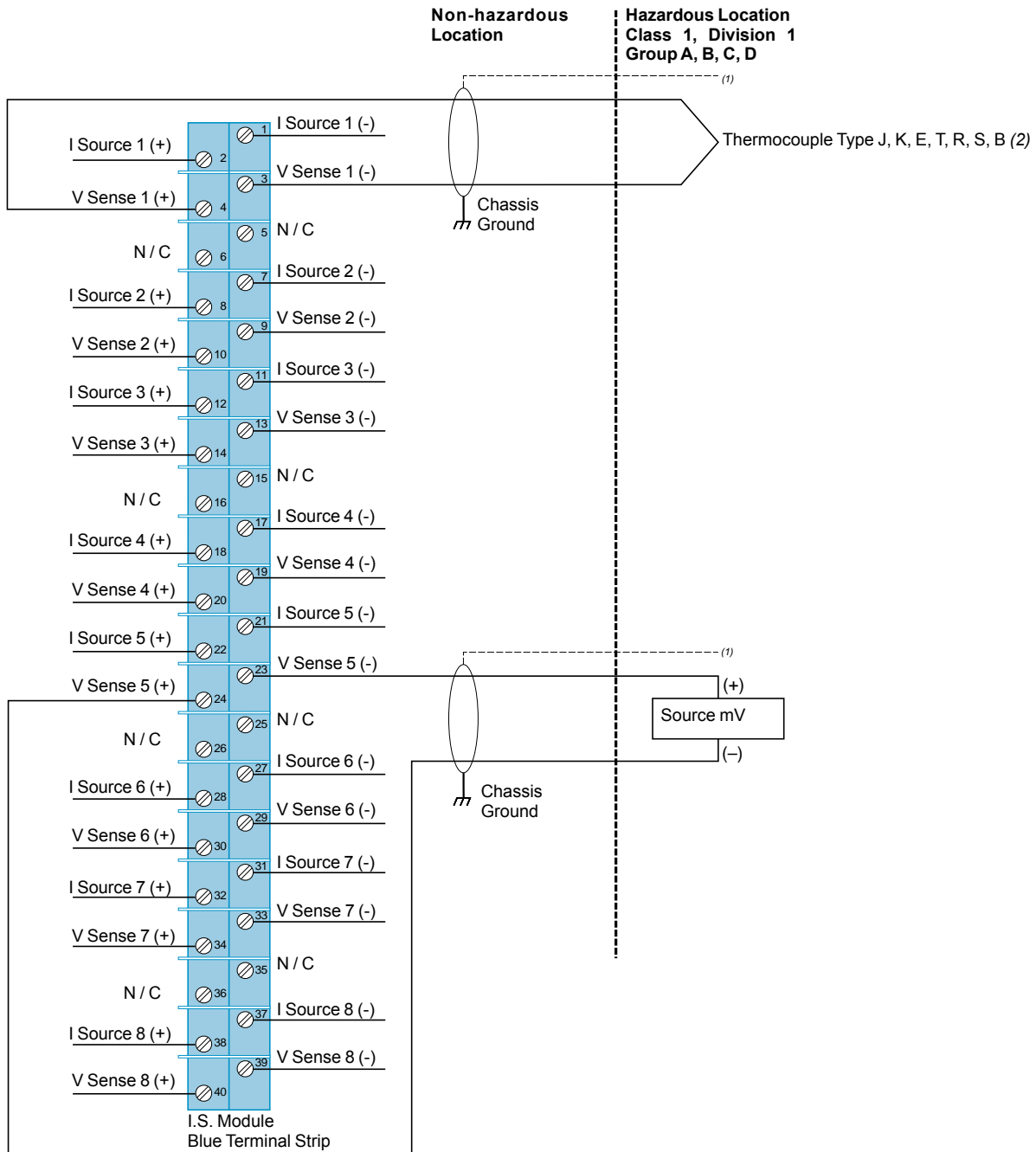

(1) Only shielded twisted pair cables should be used for connections. Shields should be left open at the field end and connected to chassis ground at the ground screws on the backplane.

(2) Pins marked "N/C" (Not Connected) are not electronically connected to the module.

Digital input module wiring diagram

140 All 330 10

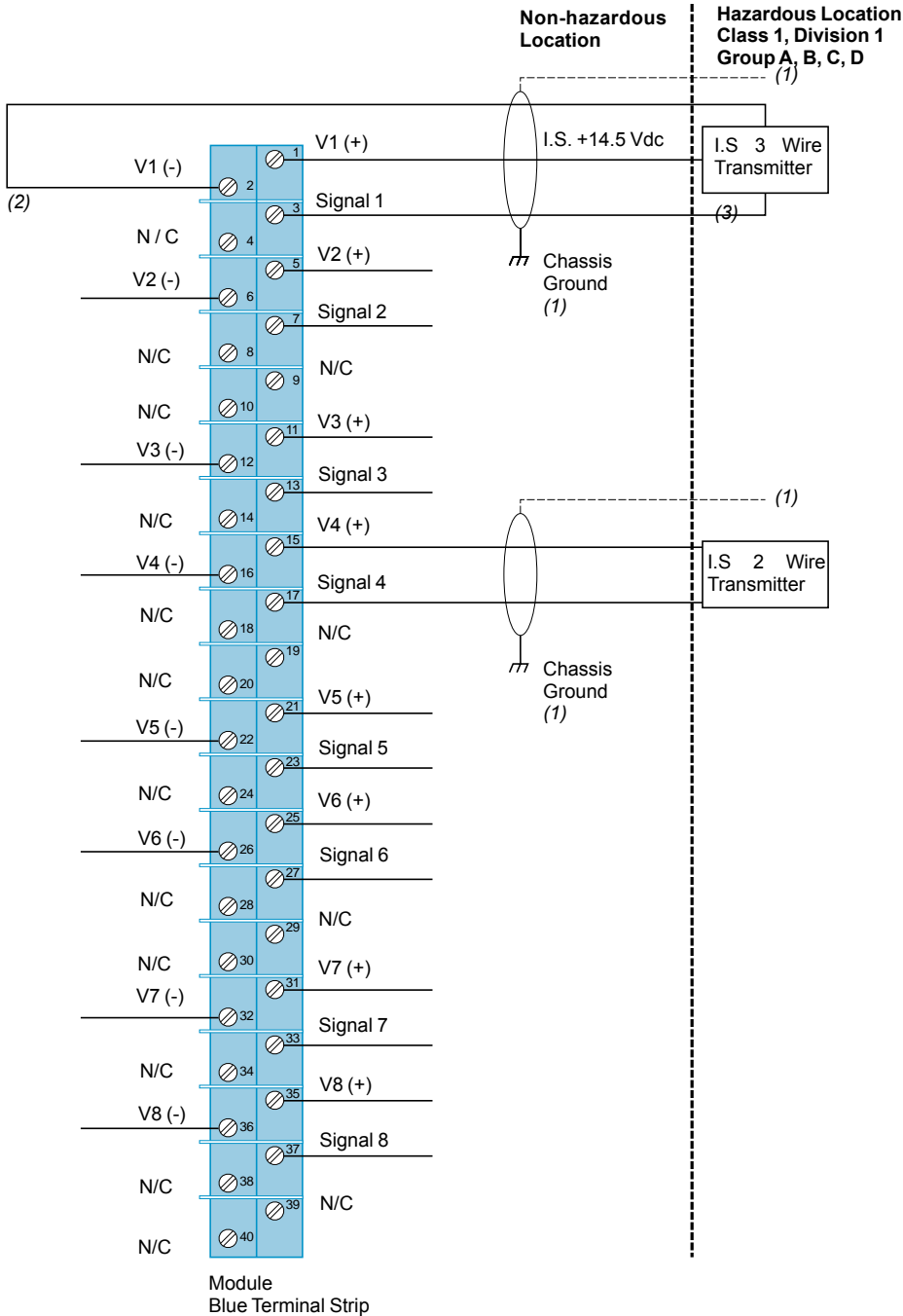

(1) Only shielded twisted pair cables should be used for connections. Shields should be left open at the field end and connected to chassis ground at the ground screws on the backplane.

(2) A dropping resistor of 100 Ohms is across the Signal and V (-) pins of each channel. V (-) is internally connected to I.S. ground.

(3) Three (3) wire transmitters should be provided power **only** from the module. An external power supply **should not** be used.

Analog output module wiring diagram

140 AIO 330 00

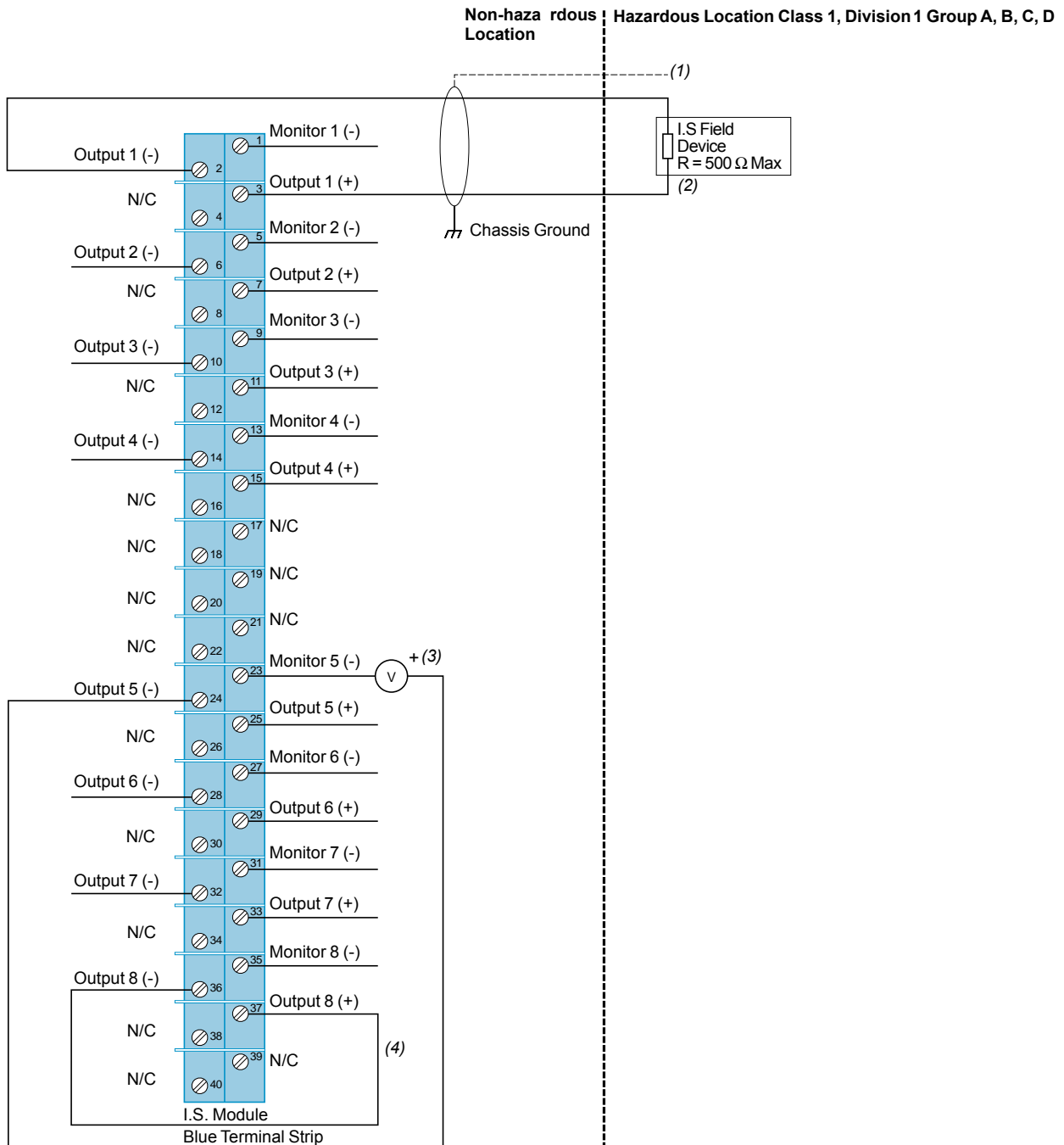

- (1) Only shielded cables should be used for connections. Shields should be left open at the field end and connected to chassis ground at the module end.
- (2) More than one device can be connected as long as they have differential input and total input resistance is less than 500 ohms.
- (3) The voltmeter is optional and reads voltage proportional to the current. Length of wiring to this terminal is limited to 1 Meter.
- (4) Unused channels will show open loop unless outputs are shorted as shown for channel 8.

Digital input module wiring diagram

140 DII 330 00

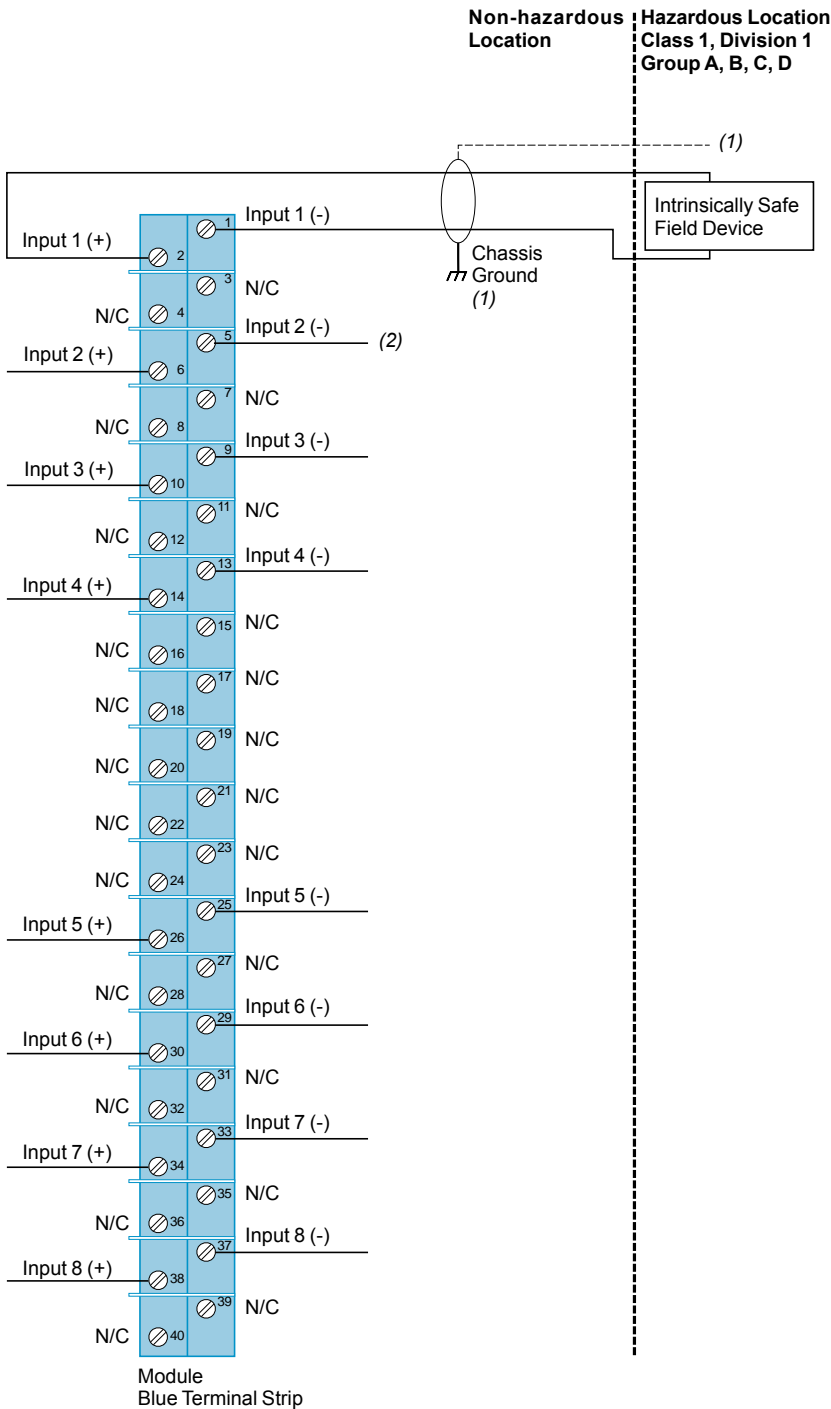

(1) Only shielded twisted pair cables should be used for connections. Shields should be left open at the field end and connected to chassis ground at the ground screws on the backplane.
 (2) All "Input" (-)s are connected together internally.

Digital output module wiring diagram

140 DIO 330 00

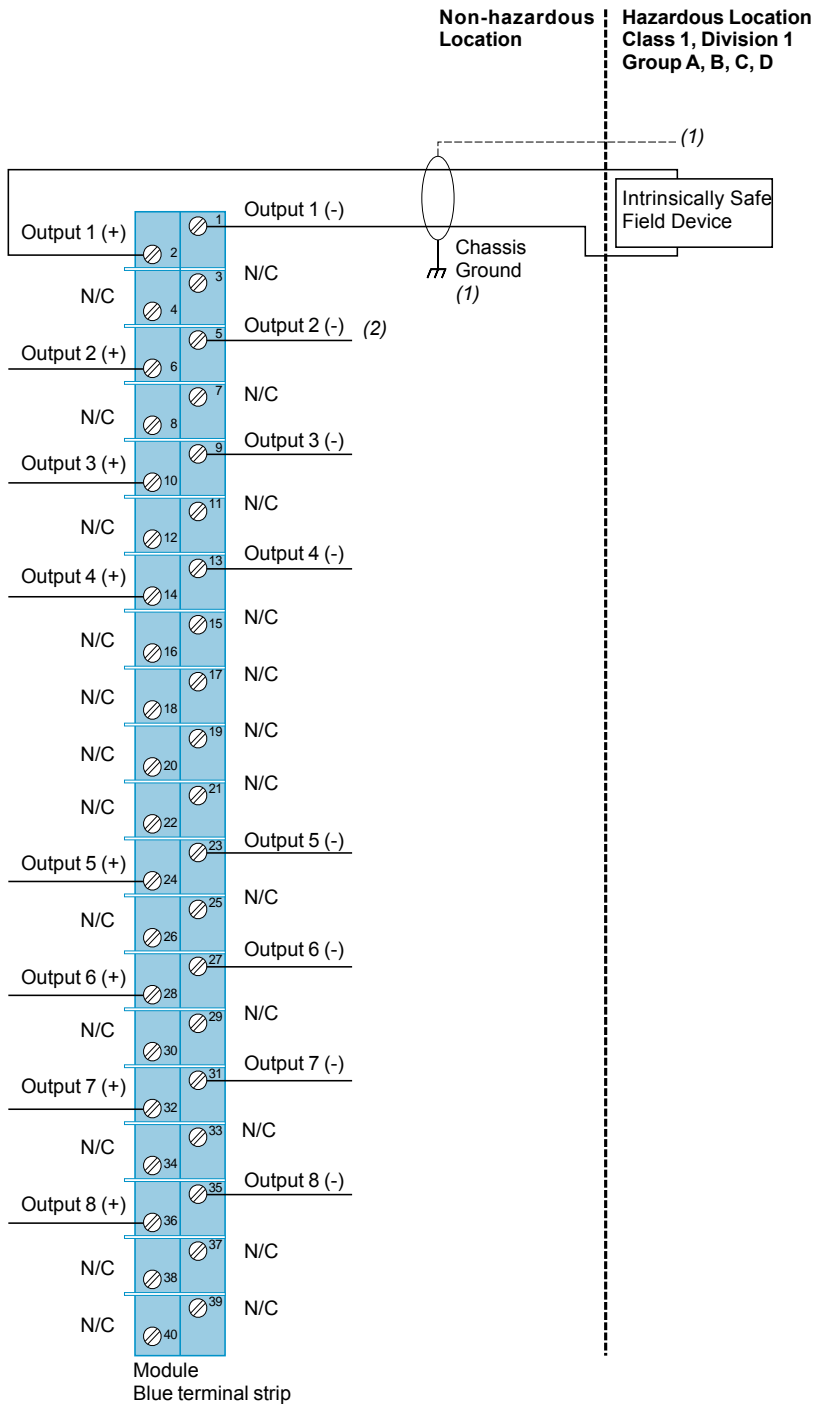

(1) Only shielded twisted pair cables should be used for connections. Shields should be left open at the field end and connected to chassis ground at the ground screws on the backplane.

(2) All "Output" (-)s are connected together internally.