

### Presentation

The Momentum analog input bases enable acquisition of various analog values encountered in industrial applications, including:

- Standard high level ( $\pm 5\text{ V}$ ,  $\pm 10\text{ V}$ ,  $1\text{-}5\text{ V}$ ,  $4\text{-}20\text{ mA}$ ,  $\pm 20\text{ mA}$ ).
- Low level ( $\pm 25\text{ mV}$ ,  $\pm 100\text{ mV}$ ).
- Thermocouples (B, E, J, ...).
- Temperature probes (Ni ..., Pt ...).

The analog output bases are used to control analog field devices such as various speed drives, proportional control valves, etc. The current or the voltage is proportional to the digital value defined by the user program. The outputs can be configured so that when the program stops the outputs either reset to zero or hold the last value received. This feature is useful during debugging since, if the outputs are set to "Hold", the operation of the analog field devices is not disturbed every time the program stops.

In order to cover a wide range of applications, Momentum I/O bases offer the following functions in addition to A/D or D/A conversion:

- Choice of input/output ranges (voltage, current, thermocouple, temperature probes).
- Selection of number of channels used.
- Cold junction compensation for thermocouple modules.
- Broken wire detection (**170 AAI 030 00**, **170 AAI 140 00**, **170 AAI 520 40**).

### Description

**170 A●●** analog I/O base units comprise on the front panel:

- 1 Internal interface connector for the communication module or processor module.
- 2 A locking and earth contact for the communication module or processor module.
- 3 LED status indicators (the number of indicators will depend on the number of channels).
- 4 Two connectors for the removable terminal blocks.
- 5 An earthing screw.
- 6 A slot for the power strip
- 7 Two screw holes for panel mounting.
- 8 A protective cover.

**Connectors to be ordered separately:**

- removable screw or spring terminal blocks **170 XTS 00● 00**.
- 1 to 3-row screw or spring bus bar **170 XTS 00● 01**.

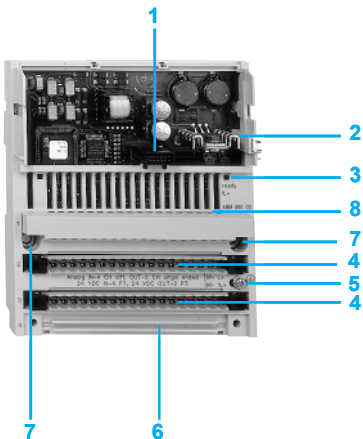

Characteristics of analog input bases							
Type of base units		170 AAI 030 00					
<b>Number of inputs</b>		1 x 8 differential inputs					
<b>LEDs</b>		Ready (green)					
<b>Format of data</b>		Full 16 bits signed (2's complement)					
<b>Protection</b>	Base and actuators	Polarity inversion					
<b>Ranges</b>			<b>± 10 VDC</b>	<b>± 5 VDC</b>	<b>4...20 mA</b>	<b>± 20 mA</b>	<b>1...5 VDC</b>
	Input impedance	kΩ	> .1000	> .1000	250	250	> .1000
	Error at 25 °C	%	0.27	0.21	0.27	0.32	0.13
	Error at 60 °C	%	0.32	0.26	0.38	0.41	0.19
	Resolution		14 bits + sign bipolar 15 bits unipolar				
<b>Conversion times</b>		<b>ms</b>	12 ms max. for 8 input channels (1.33 ms per input channel + 1.33 ms)				
<b>Error indication</b>		None					
<b>Isolation</b>	Channel to channel	<b>VDC</b>	± 200 for 1 minute				
	Field to ground	<b>VDC</b>	500 for 1 minute				
	Communication adapter to ground	<b>VAC</b>	500 for 1 minute				
<b>Common mode rejection</b>	Channel to ground		250 VAC @ 47...63 Hz or 100 VDC				
<b>Crosstalk between channels</b>		<b>dB</b>	≥ 80				
<b>External power requirement</b>	Nominal	<b>VDC</b>	24				
	Limit values	<b>VDC</b>	20.4 to 28.8				
	Current	<b>mA</b>	< 382 @ 24 VDC				
<b>EMC for industrial environment</b>	Immunity		IEC 1131 surge on auxiliary power supply 2 kV				
	Emissions		EN 50081-2				
	Approvals		UL, CSA, CE				

# Modicon Momentum automation platform

## Analog I/O bases

Characteristics of analog input bases (continued)							
Type of base units			170 AAI 140 00		170 AAI 520 40		
<b>Number of inputs</b>			1 x 16 single-ended input		1 x 4 differential inputs		
<b>Format of data</b>			Full 16 bits signed (2's complement)				
<b>Protection</b>	Base and actuators		Polarity inversion				
<b>Error indication</b>			None				
<b>Ranges</b>			<b>± 10 V</b>	<b>± 5 V</b>	<b>4...20 mA</b>	<b>± 25 mV</b>	<b>± 100 mV</b>
	Input impedance	kΩ	> 2200	> 2200	< 0.250	> 10000	> 10000
	Error at 25 °C		0.15 % FS	0.15 % FS	0.25 % FS	± 21 μV	± 27 μV
	Error at 60 °C		0.25 % FS	0.25 % FS	0.45 % FS	± 46 μV	± 94 μV
	Temperature drift (60 °C)	‰	30 PE / °C	30 PE / °C	60 PE / °C	–	–
	PE (Full scale)		10 V	5 V	16 mA	–	–
	Resolution		12 bits + sign	12 bits + sign	12 bits	15 bits + sign	
	Filtering		Low pass with cut-off frequency 10 kHz			–	
<b>Current source</b>	Pt100	mA	–	–	–	–	0.125
	Ni100	mA	–	–	–	–	0.125
	Pt1000	mA	–	–	–	0.125	–
	Ni1000	mA	–	–	–	0.125	–
<b>Update time</b>		ms	1 + 1.5 x n n = number of declared channels		500		
<b>Error indication</b>			None				
<b>Potential isolation</b>	Channel to channel	VDC	None		400		
	Base power supply and ground	VDC	500 for 1 minute		500 for 1 minute		
	Channels to ground	VAC	1780 for 1 minute		500 for 1 minute		
	Base power	V	± 30 (voltage or current output)			± 30 (voltage or current output)	
	Common mode Channel to ground	V	–		± 100 DC, 250 AC		
	Common mode Voltage between channels	V	–		200 DC, 115 AC single phase or 3-phase or 250 AC single phase		
<b>Common mode rejection</b>	Channel to ground		250 VAC at 47...63 Hz or 100 VDC			135 dB DC, 145 dB AC 50 Hz, 155 dB AC 60 Hz	
	Between channels		–			120 dB DC, 130 dB AC 50 Hz, 140 dB AC 60 Hz	
<b>Serial mode rejection</b>			–			35 dB AC 50 Hz, 45 dB AC 60 Hz	
<b>Input protection</b>			Polarity inversion				
<b>Operating voltage</b>		VDC	24				
<b>Internal current</b>		mA	305 @ 24 VDC				
<b>Power dissipation</b>	Typical	W	4.95			3.5	
	Maximum	W	5.55			5.5	
<b>Fusing</b>	Internal		2 A slow-blow			2 A slow-blow	
	External		500 mA fast-blow			500 mA fast-blow	
<b>Agency approvals</b>			UL, CE, CSA, FM Class I, Div. II				

Characteristics of analog output bases						
Type of base units		170 AAO 120 00	170 AAO 921 00			
<b>Number of outputs</b>		1 x 4				
<b>Format of data</b>		Full 16 bits signed (2's complement)				
<b>Protection</b>	Base and actuators	Polarity inversion				
<b>Ranges</b>	Load impedance	<b>kΩ</b>	<b>± 10 V</b> 1 minimum	<b>0...20 mA</b> 0.6 maximum	<b>± 10 V</b> 1 minimum	<b>4...20 mA</b> 0.6 maximum
	Capacitive load	<b>μF</b>	< 1			
	Error at 25 °C	<b>%</b>	0.2 PE	0.3 PE	0.2 PE	0.4 PE
	Error at 60 °C	<b>%</b>	0.25 PE	0.4 PE	0.25 PE	0.5 PE
	Temperature drift (60 °C)	<b>‰</b>	10 PE / °C	30 PE / °C	10 PE / °C	30 PE / °C
	Resolution		12 bits + sign			
	Update time	<b>ms</b>	< 2			
<b>Full scale</b>		10 V in the range of ± 10V 2 mA in the range of 0...20 mA				
<b>Fail State</b>		Hold, reset to zero, reset to full scale				
<b>Potential isolation</b>	Channel to channel		None			
	Base power supply and ground	<b>VDC</b>	500 for 1 minute			
	Channels to ground	<b>VAC</b>	500 for 1 minute			
	Outprotections		Short-circuits in the voltage circuits, open in current polarity inversion			
	Base power	<b>V</b>	± 30 (voltage or current output)			
<b>Common mode rejection</b>		<b>VAC</b>	250 @ 47...63 Hz or 250 DC channel to ground			
<b>Operating voltage</b>		<b>VDC</b>	24			
<b>Internal current</b>	Base	<b>mA</b>	530 @ 24 VDC			
	Actuators	<b>mA</b>	150 @ 24 VDC			
<b>Power dissipation</b>	Typical	<b>W</b>	5.6			
	Maximum	<b>W</b>	8.5			
<b>Internal fusing</b>		<b>A</b>	2, slow-blow			
<b>Agency approvals</b>			UL, CE, CSA			

Characteristics of discrete and analog I/O bases							
Type of base unit		170 AMM 090 00	170 AMM 090 01				
<b>Number of inputs and outputs</b>		1 x 4 differential inputs 1 x 4 discrete inputs 1 x 2 analog outputs 1 x 2 discrete outputs					
<b>Operating voltage</b>		<b>VDC</b> 24	12				
<b>Internal current</b>		<b>mA</b> 200 typical (at 24 VDC), 350 maximum (at 24 VDC)	700 maximum (at 12 VDC)				
<b>Differential inputs for 170 AMM 090 00/090 01</b>	Conversion time	10 ms for all channels					
	Conversion error	<b>%</b>	<b>± 10 V</b>	<b>± 5 V</b>	<b>1...5 V</b>	<b>± 20 mA</b>	<b>4...20 mA</b>
		25 °C	0.08	0.16	0.16	0.16	0.16
	60 °C	0.15	0.3	0.3	0.3	0.3	
	Resolution		14 bits	13 bits	12 bits	13 bits	12 bits
	Conversion consistency	<b>%</b>	± 0.02	± 0.04	± 0.04	± 0.04	± 0.04
	Common mode voltage		Input voltage starting at Ag ± 11 V				
	Common mode suppression	<b>dB</b>	> 54		80		
	Overvoltage	<b>V</b>	± 30 solid state if voltage is 24 V		± 30 solid state if voltage is 12 V		
	Voltage ranges		± 50 dynamic max. 100 ms		± 50 dynamic max. 100 ms		
	Overvoltage current ranges	<b>mA</b>	-		> 48		
	Input resistance	<b>Ω</b>	1 M		250		
Fail state		Hold or reset to zero					
<b>Discrete inputs</b>	Voltage	<b>VDC</b>	24 typical, 30 maximum		12 typical		
	Signal Type		True high				
	On Voltage	<b>VDC</b>	+ 11...+ 30		+ 7.5...+ 15		
	Off Voltage	<b>VDC</b>	- 3...+ 5		- 1.5...+ 2.5		
	Input current	<b>mA</b>	2.5 minimum at state 1 (6 mA at operating voltage), 1.2 maximum at state 0				
	Input resistance	<b>kΩ</b>	4		2.1		
	Response time	<b>ms</b>	2.2 from 0 to state 1 3.3 from 1 to state 0				
<b>Analog outputs</b>	Resolution		12 bits for single-phase measuring range 0...20 mA, 12 bits for 2-phase measuring range ± 10 V				
	Conversion time	<b>ms</b>	1 for all channels				
	Conversion error		max. ± 0.35 % of upper measuring range value				
	60 °C		max. ± 0.70 % of upper measuring range value				
	Output load		≥ 3 kΩ for voltage output, ≤ 600 Ω for current output				
<b>Discrete outputs</b>	Voltage	<b>VDC</b>	24 typical, 30 maximum				
	Type		Semiconductor				
	Signal Type		True high				
	Current capacity		1 per channel, 2 per group, 2 per module				
	Leakage current	<b>mA</b>	< 1 @ 24 VDC		< 1 @ 12 VDC		
	On State Voltage drop	<b>VDC</b>	< 0.5 @ 1 A		< 0.5 @ 0.5 A		
	Response time	Off to On	<b>ms</b>	< 0.1			
		On to Off	<b>ms</b>	< 0.1			
	Output protection		The outputs are protected against overload and short-circuit-circuiting				
	Output indicator		1 red LED per "On" output in the event of an overload or short-circuit-circuiting				
	Error message		Message "I/O error" on bus adapter if module is defective				
	Max. Switching cycles		1000/hr (inductive load 1 A), 100/s (resistive load 1 A), 8/s (filament load 2.4 W)				
	<b>Potential isolation</b>	Discrete input and output		None			
Analog input to output			None				
Analog input and output and to operating voltage		<b>VAC</b>	500 for 1 minute				
Operating voltage and all inputs and outputs from ground		<b>VAC</b>	500 for 1 minute				
<b>Power dissipation</b>	Typical	<b>W</b>	4.0				
	Maximum	<b>W</b>	6.0				
<b>Agency approvals</b>			UL, CE, CSA, FM Class I, Div. II		UL, CE, CSA		

Characteristics of discrete and analog I/O bases (continued)				
Type of base unit		170 ANR 120 90	170 ANR 120 91	
<b>Number of inputs and outputs</b>		1 x 6 analog inputs 2 x 4 discrete inputs 1 x 4 analog outputs 1 x 8 discrete outputs		
<b>Operating voltage</b>		<b>VDC</b>	24, range 19.2...30	
<b>Internal current</b>		<b>mA</b>	400 @ 24 VDC	
<b>Analog inputs</b>	Resolution		14 bit	
	Input range	<b>VDC</b>	0...10   - 10...+ 10	
	Input type		Single-ended	
	Conversion time		0.75 ms maximum for 6 input channels	
	Conversion error		0.2 % @ 25 °C for 0 - 10 VDC inputs	
	Max input signal	<b>VDC</b>	15 for voltage input	
	Max temperature drift	<b>VDC</b>	10 inputs	
	Input resistance	<b>MΩ</b>	>1 for voltage inputs	
<b>Discrete inputs</b>	Voltage	<b>VDC</b>	24	
	Configuration		2 groups of 4 inputs	
	Signal Type		True high	
	Minimum on voltage	<b>VDC</b>	> 11	
	Maximum off voltage	<b>VDC</b>	< 5	
	Input current	Minimum On	<b>mA</b>	6
		Maximum Off	<b>mA</b>	2
	Input voltage	Range	<b>VDC</b>	+ 3...+ 32
		Surge	<b>VDC</b>	45 peak for 10 ms
	Response time	Off to On	<b>ms</b>	1.2,
On to Off		<b>ms</b>	1.2	
<b>Analog outputs</b>	Resolution		14 bit	
	Output range	<b>VDC</b>	0...10   - 10...+ 10	
	Conversion time	<b>ms</b>	1.20 for all four channels	
	Conversion error		max. + 0.4 % of upper measuring range value @ 25 °C	
	Output load		> 2 kΩ minimum @ 0...10 VDC	
	Fail state		Hold or reset to zero	
<b>Discrete outputs</b>	Voltage	<b>VDC</b>	10-30 operating, 50 for 1 ms maximum	
	Type		Solid State Switch	
	Signal type		True high	
	Current capacity	<b>A</b>	0.25 per point, 2 per group, 2 per module	
	Leakage current	<b>mA</b>	0.4 @ 30 VDC	
	Surge current	<b>A</b>	2.5 for 1 ms	
	On state voltage drop	<b>VDC</b>	< 0.4 @ 0.25 A current	
	Response time	Off to On	<b>ms</b>	1.2
		On to Off	<b>ms</b>	1.05
	Output protection		The Outputs are protected against overload and short-circuiting	
	Output indicator		1 LED per point	
<b>Potential isolation</b>	Discrete input to output		None	
	Analog input to output		None	
	Analog input and output to operating voltage	<b>VAC</b>	500 for 1 minute.	
	Operating voltage and all inputs and outputs from ground	<b>VAC</b>	500 for 1 minute	
<b>Power dissipation</b>	Typical	<b>W</b>	4.0	
	Maximum	<b>W</b>	6.0	
<b>Agency approvals</b>			UL, CE, CSA	

# Modicon Momentum automation platform

## Analog I/O bases



170 AAI 000 00



170 AAO 020 00



170 AAM 090 00

### Analog input bases

Type of inputs	Number of channels	Ranges	Reference	Weight kg
12 bits + sign	16 single-ended	$\pm 5\text{ V}$ , $\pm 10\text{ V}$ , 4-20 mA	170 AAI 140 00	0.215
15 bits + sign	4, differential	Pt 100, Pt 1000, NI 100 thermocouples B, E, J, K, N, R, S, T	170 AAI 520 40	0.215
	8, differential	$\pm 5\text{ V}$ , $\pm 10\text{ V}$ , 1-5V $\pm 20\text{ mA}$ , 4-20 mA	170 AAI 030 00	0.215

### Analog output bases

Type of outputs	Number of channels	Ranges	Reference	Weight kg
12 bits + sign	4	$\pm 10\text{ V}$ , 0-20 mA	170 AAO 120 00	0.215
		$\pm 10\text{ V}$ , 4-20 mA	170 AAO 921 00	0.215

### Discrete and analog I/O bases

Type	Inputs	Outputs	Ranges	Reference	Weight kg
13 bits + sign	4 differential analog 12 bits	2 analogs 12 bits	$\pm 5\text{ V}$ , $\pm 10\text{ V}$ 1-5 V $\pm 20\text{ mA}$ 4-20 mA	170 AMM 090 00	0.240
			24 VDC		
13 bits + sign	4 differential analog 12 bits	2 analogs 12 bits	$\pm 5\text{ V}$ , $\pm 10\text{ V}$ 1-5 V $\pm 20\text{ mA}$ 4-20 mA	170 AMM 090 01	0.240
			12 VDC		
14 bits	6 analog 14 bits	4 analogs 14 bits	0-10 V	170 ANR 120 90	0.240
			24 VDC		
14 bits	6 analog 14 bits	4 analogs 14 bits	$\pm 10\text{ V}$	170 ANR 120 91	0.240
			24 VDC		



170 XTS 001 00



170 XTS 002 00

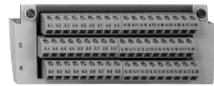

170 XTS 004 01



170 XTS 005 01



170 XTS 008 01



170 XTS 006 01

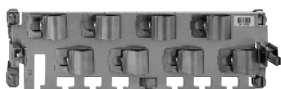

CER 001

### Accessories

Description	Composition	Type of connection	Reference	Weight kg
Terminal blocks	Set of 3 connectors	Screw	170 XTS 001 00	—
	1 row	Spring	170 XTS 002 00	—
Bus Bar	3 rows	Screw	170 XTS 004 01	—
		Spring	170 XTS 003 01	—
	2 rows	Screw	170 XTS 005 01	—
		Spring	170 XTS 008 01	—
	1 rows	Screw	170 XTS 006 01	—
		Spring	170 XTS 007 01	—
Cable Grounding Rail	Used to connect the cable shielding		CER 001	—
High vibration environment clips	Used to prewire the I/O base units. Requires screw or spring connection terminals		170 BDM 090 00	—

### Replacement parts

Description	Use	Reference	Weight kg
Sheets of labels	10 front labels for Momentum modules	170 XTS 100 00	—
Set of coding and locating device	For screw or spring connection terminals	170 XCP 200 00	—

### Dimensions, mounting

170 A●●

Rail or panel mounting

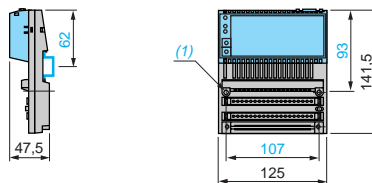

(1) 2 holes for M4 screws, for panel mounting.

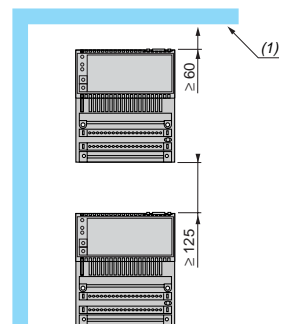

(1) Equipment or enclosure.

### Connections of analog input bases and analog output bases

170 AAI 030 00

Example of external wiring of 2-wire sensor

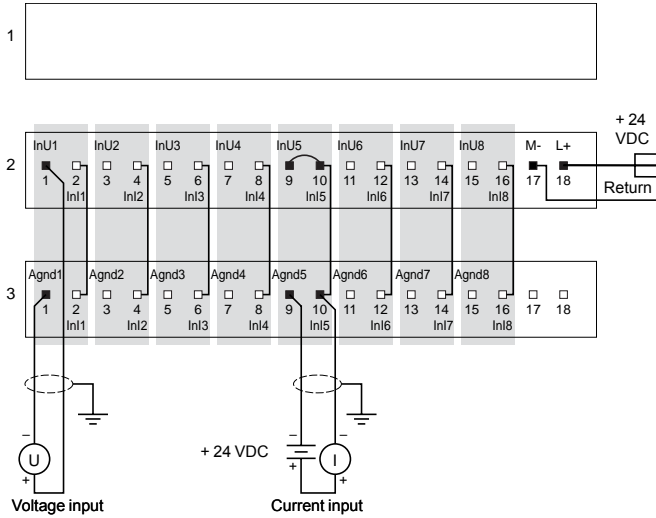

170 AAI 140 00

Example of external wiring of 2-wire sensor

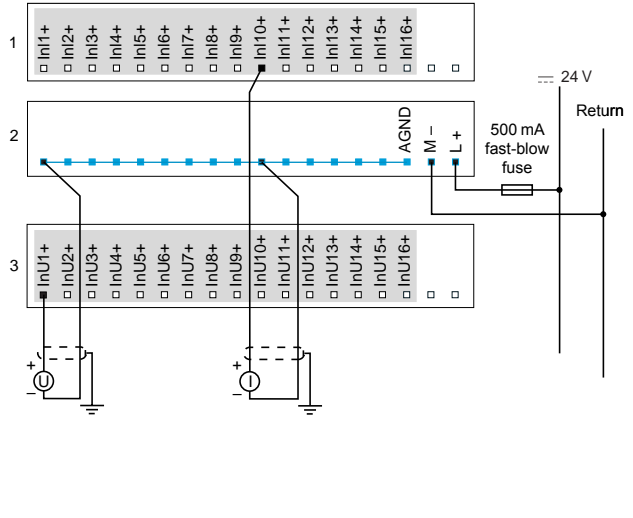

Group of channels

Internal wiring

170 AAI 520 40

Example of external wiring of sensor

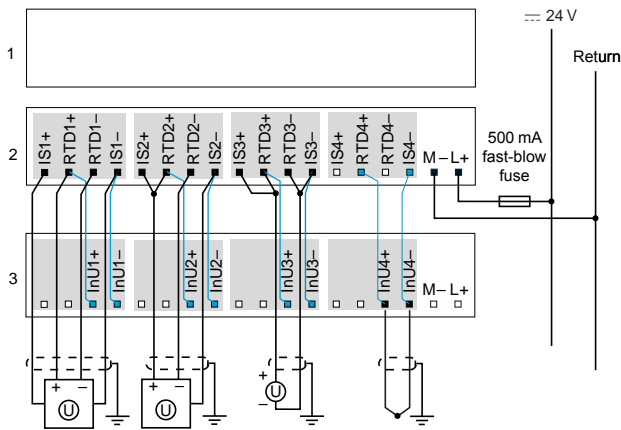

Group of channels

Internal wiring

170 AAO 120/921 00

Example of external wiring of 2-wire actuator

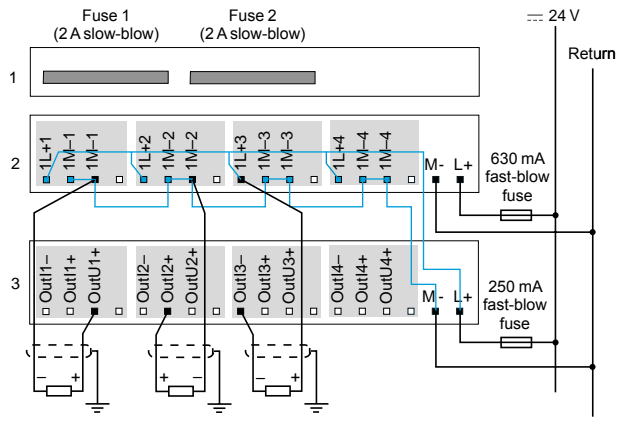

Group of channels

Internal wiring

### Connections of discrete and analog bases

170 AMM 090 00/AMM 090 01

Example of external wiring of 2-wire sensor

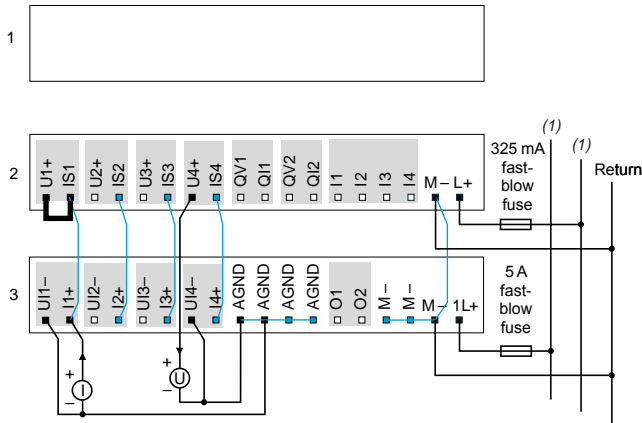

Example of external wiring of 2-wire actuator

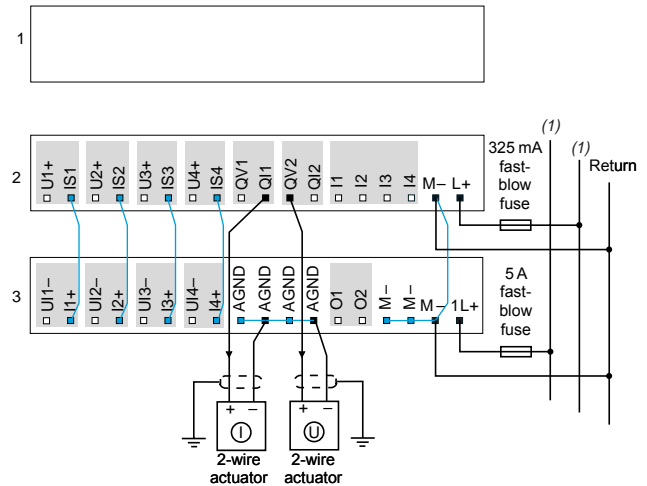

External bridge

External bridge

Group of channels

Internal wiring

Group of channels

Internal wiring

170 AMM 090 00/AMM 090 01 (continued)

Example of external wiring of digital sensor/actuator

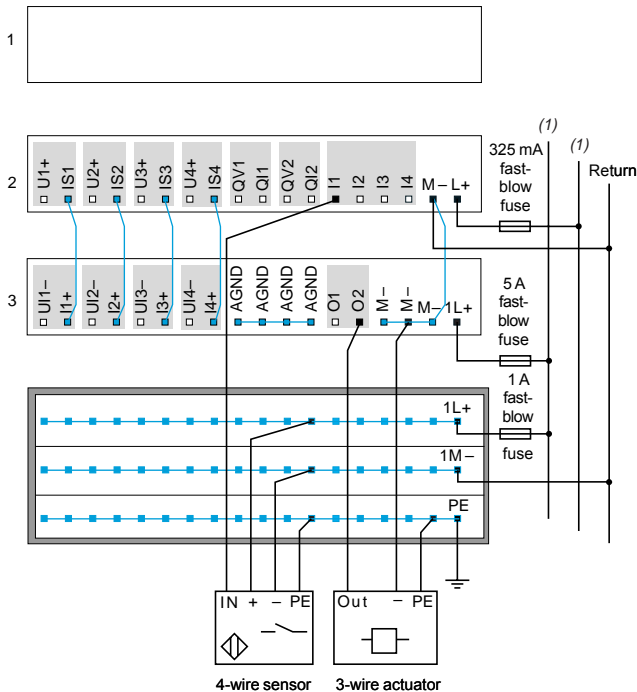

4-wire sensor 3-wire actuator

Group of channels

Internal wiring

170 ANR 120 90/91

Example of mixed discrete and analog I/O sensor/actuator field wiring

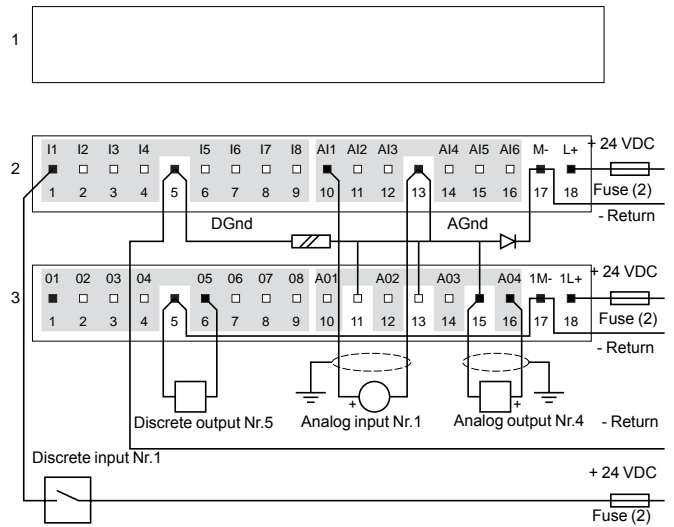

(1) ∴ 24 V for 170 AMM 090 00, ∴ 12 V for 170 AMM 090 01.  
 (2) Depending on application, max 5 A.