

# EH4700DB Series Enclosure

## OUTDOOR, SMALL/MEDIUM, TOP MOUNTING, "DROP" BOTTOM

### Product Features

- Indoor/Outdoor Applications
- All-Aluminum Construction
- Bottom-Opening Access Door
- Factory/Field-Installed Accessories
- Cable Entry Glands and Mounting Holes Located on Top of Enclosure
- Suitable for Mounting in Parking Garages and Under Building Eaves or Installations Where Wall Mounting Is Not Practical



EH4718DB ENCLOSURE

The **EH4700DB Series** are indoor/outdoor enclosures constructed from die cast and extruded aluminum. They are available in 13-inch (33.02 cm) (**EH4712DB**) or 18-inch (45.72 cm) (**EH4718DB**) lengths.

Both enclosures will accept cameras with either fixed focal length lenses or motorized zoom lenses. Models with factory-installed heater and blower feature a prewired PC board with internal electronics to simplify installation and setup of camera and enclosure accessories.

Unlike other enclosures, the **EH4700DB Series** opens from the bottom and the camera sled is attached to the top of the enclosure. Internal adjustments can be made without interfering with the video because the camera remains in its normal viewing position.

Cable entry glands and mounting holes are located on the top of the enclosure, making it ideal for ceiling applications, especially where limited accessibility is a concern.

The **EH4700DB Series** is available with factory-installed heaters and blowers. Optional field-installed accessories include a window defroster, preset positioning lens wiring harness, 120 VAC electrical outlet, and lock kit.

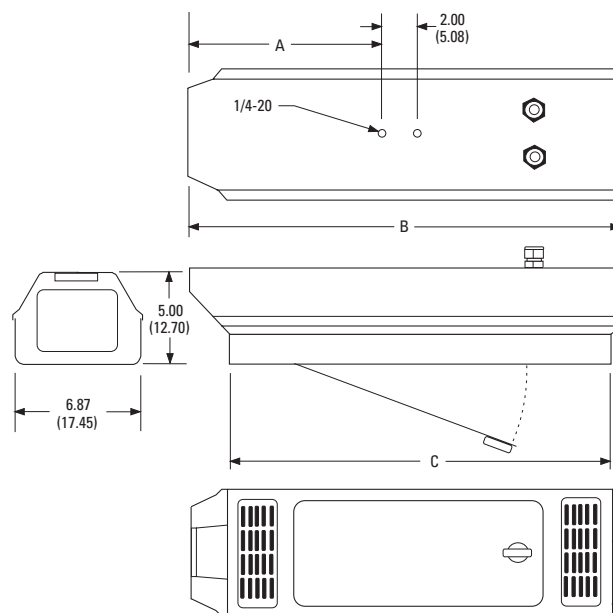

NOTE: EH4712DB SERIES DOES NOT HAVE VENTS IN BOTTOM OF ENCLOSURE.

	EH4712DB	EH4718DB
A	7.25 (18.42)	9.25 (23.50)
B	16.2 (41.15)	21.2 (53.84)
C	13.3 (33.78)	18.3 (46.48)

NOTE: VALUES IN PARENTHESES ARE CENTIMETERS; ALL OTHERS ARE INCHES.



# TECHNICAL SPECIFICATIONS

## MODELS

Model Number	Basic Enclosure	120 VAC	24 VAC	230 VAC	Heater	Defroster	Blower	Max. Power Consumption*
EH4712DB	•							
EH4712DB-1		•			•		•	68W
EH4712DB-2			•		•		•	58W
EH4712DB-3				•	•		•	63W
EH4718DB	•							
EH4718DB-1		•			•		•	68W
EH4718DB-2			•		•		•	58W
EH4718DB-3				•	•		•	63W

\*If optional defroster is used, add 15W to consumption.

## MECHANICAL

Cable Entry	Two PG13.5 UL compression glands on lid; maximum cable diameter 0.47 inch (1.19 cm)
Cable Entry Holes	0.875-inch (2.22 cm) diameter; will accept 0.5-inch (1.27 cm) conduit fitting when gland is removed
Camera Mounting	Removable camera sled
Access Door Latch	1/4-turn latch with molded vinyl cap

## ELECTRICAL

Input voltage	24 VAC, 120 VAC, or 230 VAC, 50/60 Hz		
Electrical connection	Connectors for power input, lens, camera, and accessories (-1/-2/-3 models only)		
Power consumption	120 VAC	24 VAC	230 VAC
Heater	60 watts	50 watts	55 watts
Defroster	15 watts	15 watts	15 watts
Blower	8 watts	8 watts	8 watts

## GENERAL

Maximum Camera and Lens Size*	(including BNC connector)
EH4712DB	12.5" L x 3.5" W x 4.0" H (31.75 x 8.89 x 10.16 cm)
EH4712DB-1/-2/-3	8.5" L x 3.5" W x 4.0" H (21.59 x 8.89 x 10.16 cm)
EH4718DB	16.5" L x 3.5" W x 4.0" H (41.91 x 8.89 x 10.16 cm)
EH4718DB-1/-2/-3	12.5" L x 3.5" W x 4.0" H (31.75 x 8.89 x 10.16 cm)
Viewing Window	0.25-inch (6.35 mm) thick Lexan®
Viewing Window Area	3.50" H x 4.00" W (8.89 x 10.16 cm)
Construction Environment	Die-cast, extruded, and sheet aluminum Indoor/outdoor -10° to 120°F (-23° to 49°C)
Weight	<u>Unit</u> <u>Shipping</u>
EH4712DB	6.35 lb (2.90 kg)              7 lb (3.17 kg)
EH4712DB-1/-2/-3	7.85 lb (3.56 kg)              9 lb (4.08 kg)
EH4718DB	7.25 lb (3.28 kg)              9 lb (4.08 kg)
EH4718DB-1/-2/-3	8.75 lb (3.96 kg)              10 lb (4.53 kg)

\*Assumes lens is fully extended.

## CERTIFICATIONS/RATINGS

- CE compliant (EH4712DB, EH4712DB-2, EH4712DB-3, EH4718DB, EH4718DB-2 and EH4718DB-3 only)
- Meets NEMA Type 3R standards

## OPTIONAL ACCESSORIES

<b>Window Defroster</b>	WD47-1*	Window defroster and defogger prevents ice buildup or condensation of moisture on window caused by temperature and humidity, 120 VAC, 15W
	WD47-2*	Same as WD47-1 except 24 VAC operation
	WD47-3*	Same as WD47-1 except 230 VAC operation
<b>Other</b>	LK4500	Lock kit
	O/I-LPP	Preset positioning lens wiring harness (for use with -1/-2/-3 models only)
	O/I-OUTLET	120 VAC electrical outlet (for use with -1/-2/-3 models only)

\*Window defroster not for use with basic enclosure (EH4712DB or EH4718DB).

## RECOMMENDED MOUNTS

<b>Ceiling</b>	EM1009U, EM1015U	Medium duty ceiling mount; maximum load 40 lb (18.14 kg)
<b>Wall</b>	EM1900U	Medium duty wall mount; maximum load 40 lb (18.14 kg)
<b>Pipe/Pole</b>	EM1109	Medium duty ceiling/pedestal mount for horizontal pipe or pole applications; maximum load 40 lb (18.14 kg)
	EM2000	Medium duty mount for vertical pipe or pole applications; maximum load 40 lb (18.14 kg) (Mount orientation is reversed when used with EH4718DB Series)

## RECOMMENDED PAN/TILT

### (Inverted Operation Only)

PT570-24P Series	Medium duty indoor/outdoor pan/tilt, 24 VAC; maximum load 40 lb (18.14 kg)
------------------	--



**Pelco, Inc. Worldwide Headquarters:**  
3500 Pelco Way, Clovis, California 93612-5699 USA  
**USA & Canada** Tel: (800) 289-9100 • FAX: (800) 289-9150  
**International** Tel: +1 (559) 292-1981 • FAX: +1 (559) 348-1120  
[www.pelco.com](http://www.pelco.com)

Pelco and the Pelco logo are registered trademarks of Pelco, Inc.  
Lexan is a registered trademark of the General Electric Company.  
Product specifications and availability subject to change without notice.  
©Copyright 2002, Pelco, Inc. All rights reserved.