

Modicon Quantum automation platform

Analog I/O

Description

The Modicon Quantum automation platform supports a full range of analog I/O modules designed to interface with a wide variety of field devices. All modules meet internationally accepted IEC electrical standards that ensure reliability in harsh operating environments. For even better protection and extended life in extremely harsh environments, you can have your modules conformally coated.

Fully software-configurable

All Quantum I/O modules can be completely configured using Unity Pro, Concept or ProWORX. The ability to specify an I/O address for each module in software makes it easy to add or change modules in your configuration without physically changing the application program.

I/O Map zooming

Analog and special-purpose modules frequently require that you specify particular modal or operational parameters for different functions in addition to the standard I/O addressing requirements. Quantum's ability to configure multi-function modules via software eliminates the need for traditional hardware DIP switches or complex application programming. A software capability called I/O Map zooming allows you to zoom into a setup screen where you can initialize or change the module's operating parameters. This I/O Map zoom technique is used on multi-function analog input modules, high-speed counters, single-axis motion modules and temperature-sensing modules such as thermocouples and RTDs.

Defining the failure mode of an output module

Quantum gives you the ability to predefine how an analog output channel will respond if for any reason the module stops being serviced. You can configure the module in software so that the output channels:

- Go to zero.
- Go to a predefined safe state.
- Hold the last value they received before the watchdog timer expired.

Failure modes can be defined on a channel-by-channel basis. In the event of a complete module failure, the fail state settings you have specified can be sent to the replacement module.

Mechanical keying for added security

Optionally, you can insert mechanical keys between the I/O module and the terminal strip to ensure that the field wiring and the module type are properly matched. Keying codes are unique for each module type. You can also implement mechanical keying for unique slot locations so that a rack full of similar modules with similar keying codes will not be incorrectly connected. Keys are shipped with the I/O modules. They do not need to be ordered separately.

I/O connectors

Each I/O module requires an I/O connector (P/N 140 XTS 002 00), which can be ordered separately. The same connector can be used with all modules, **sauf pour les modules de sécurité intrinsèque.**

Modicon Quantum automation platform

Analog I/O

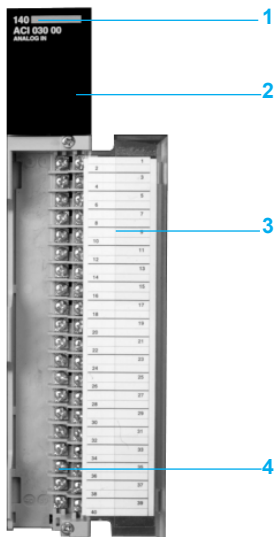

Description

The front panel of 140 A●/A●O/AMM analog input or output modules comprises:

- 1 A model number and color code.
- 2 A LED indicator panel.
 - Active (green): bus communication is present been detected,
 - F (red): a fault (external to the module) has been detected,
 - 1...16 (green): the indicated point or channel is turned on,
 - 1...16 (red): there is a fault on the indicated point or channel.
- 3 A removable, hinged door and customer identification label.
- 4 A terminal block,40-pole (140 XTS 002 00) must be ordered separately.

Input module characteristics					
Model		140 ACI 030 00	140 AVI 030 00		
Number of channels			8 differential		
Addressing requirements			9 input words		
Input ranges (selectable on a per channel basis)	Bipolar	–	± 10 V	± 5 V	± 20 mA
	Unipolar	–	0...10 V	0...5 V	0...20 mA
	Unipolar w/offset	–	1...5 V	4...20 mA	
Voltage input	Linear measuring range		(input range) x 1.024		
	Absolute maximum	V	50		
	Impedance	MΩ	> 20		
Current input	Linear measuring range	mA	4...20	(input range) x 1.024	
	Absolute maximum	mA	25		
	Impedance	Ω	250 ± 0.03%		
Absolute accuracy error @ 25° C (voltage mode)	Typical		± 0.05% of full scale	± 0.03%	
	Maximum		± 0.1% of full scale	± 0.05% of full scale	
Linearity			± 0.04%	± 0.008%	
Accuracy drift w/temperature	Typical		± 0.0025% of full scale / °C	± 0.0015% of full scale / °C	
	Maximum		± 0.005% of full scale / °C	± 0.004% of full scale / °C	
Common mode rejection		dB	> - 72 @ 60 Hz	> - 80 @ 60 Hz	
Input filter			Single pole low pass, - 3 dB cutoff @ 15 Hz, ± 20%	Single pole low pass, - 3 dB cutoff @ 847 Hz, ± 20%	
Isolation	Channel-to-bus	z	± 1000 V, 3000 Vpp, for 1 minute	± 750 V, ~ 500 V rms, for 1 minute	
	Channel-to-channel	z	± 30 V max.	± 200 V, ~ 135 V rms max.	
Update time		ms	5 for a all channels	10 for a all channels	
Fault detection			Broken wire (4...20 mA mode) or under voltage range (1...5 V)	Broken wire in 4...20 mA mode Out of range @ 1...5 V	
Bus current requirement		mA	240	280	
Power dissipation		W	2	2.2	
External power			–		
Resolution		bits	12	16 for $\pm \pm 10$ V, 0...10 V. 15 for $\pm \pm 5$ V, 0...5 V, ± 20 mA, 0...20 mA. 14 for $\pm 1...5$ V, 4...20 mA	
Agency approvals			UL 508, CSA 22.2-142, FM Class1 Div.2, C€, cUL (pending)	UL 508, CSA 22.2-142, FM Class1 Div.2, C€, cUL	

Input module characteristics				
Model		140 ARI 030 10	140 ACI 040 00	
Number of channels		8	16 differential or 16 externally tied single ended	
Addressing requirements		9 input words	17 input words	
RTD types (configurable)				
IEC platinum	Pt 100, Pt 200, Pt 500, Pt 1000	°C	-200... + 850	–
American platinum Nickel	Pt 100, Pt 200, Pt 500, Pt 1000	°C	-100... + 450	–
	Ni 100, Ni 200, Ni 500, Ni 1000	°C	-60... + 180	–
Measurement current	Pt 100, Pt 200, Ni 100, Ni 200	mA	2.5	–
	Pt 500, Pt 1000, Ni 500, Ni 1000	mA	0.5	–
Input impedance		MΩ	>10	250 Nominal
Module ranges and resolution		0.1 °C	0.0...25 mA, 0...25,000 counts 0.0...20 mA, 0...20,000 counts 4.0...20 mA, 0...16,000 counts (default range) 4.0...20 mA, 0...4,095 counts	
Accuracy error @ 25 °C		–	± 0.125% of full scale	
Linearity (0 ... 60 °C)		± 0.01% of full scale ± 0.5 °C	± 12 µA max. 4...20 mA range, 0...4,095 counts ± 6 µA max. 0...25 mA range, 0...25,000 counts ± 6 µA max. 0...20 mA range, 0...20,000 counts ± 6 µA max. 4...20 mA range, 0...16,000 counts	
Absolute maximum input		mA	–	30
Absolute drift w/temperature		°C	± 0.5 (25 °C) ± 0.9 (0...60 °C)	Typical: 0.0025% of full scale Maximum: 0.0050% of full scale
Isolation	Channel-to-channel		300 V peak-to-peak	–
	Channel-to-bus		~ 1780 V @ 47...63 Hz for 1 minute or ~ 2500 V for 1 minute	~ 1780 V for 1 minute
Working voltage		DC	–	30
Input filter			–	Single pole low pass, - 3 dB cutoff @ 34 Hz, ± 25%
Common mode rejection			–	> - 90 dB @ 60 Hz
Update time (all channels)	2-wire/4-wire	ms	640	15 for all 16 channels
	3-wire	s	1.2	–
Fault detection			Out of range or 8 red LEDs to indicate broken wire conditions	Open circuit in 4... 20 mA mode. Specific channel is identified when an open circuit is detected and is reported back to the controller in the 17th input Word.
Bus current requirement		mA	200	360
Power dissipation		W	1	5.0
Agency approvals			UL 508, CSA 22.2-142, FM Class1 Div.2, C€, cUL	UL 508, CSA 22.2-142, FM Class1 Div.2, C€, cUL (pending)

Input module characteristics		
Model	140 ATI 030 00	
Number of channels		8
Addressing requirements		10 input words
TC types and ranges	J	°C - 210 ... +760
	K	°C - 270 ... +1370
	E	°C - 270 ... +1000
	T	°C - 270 ... + 400
	S	°C - 50 ... +1665
	R	°C - 50 ... +1665
	B	°C - 130 ... +1820
	Millivolt ranges	mV
TC resistance /Max Source Resistance	W	200 max. for rated accuracy
Input impedance	MΩ	> 1
Input filter		Single low pass @ nominal 20 Hz, plus notch filter @ 50/60 Hz
Normal noise rejection	dB	120 min. @ 50 or 60 Hz
Cold junction compensation (CJC)		Internal CJC operates between 0 ... 60 °C (errors are included in the accuracy specification). The connector door must be closed. Remote CJC can be implemented by connecting a thermocouple (which monitors the external junction block temperature) to channel 1. Types of thermocouples J, K, and T are recommended for remote CJC.
Resolution	TC ranges	Choice of : 1 °C (default), 0.1 °C, 1 °F, 0.1 °F
	Millivolt ranges	100 mV range, 3.05 μV (16 bits) 25 mV range, 0.76 μV (16 bits)
TC absolute accuracy	Types J, K, E, T	± 2 °C plus + 0.1% of reading
	Types S, R, B	± 4 °C plus + 0.1% of reading
Millivolt absolute accuracy	@ 25 °C	± 20 μV + 0.1 % of reading
	Accuracy drift w/temperature	0.15 μV / °C + 0.0015% of reading / °C max
Isolation	Channel-to-bus	~ 1780 V @ 47... 63 Hz for 1 minute or ≡ 2500 V for 1 minute
	Channel-to-channel	~ 220 V @ 47... 63 Hz or ≡ 300 V max.
Update time (all channels)	s	1
Fault detection		8 red LEDs to indicate out of range or broken wire conditions
Bus current requirement	mA	280
Power dissipation	W	1.5
External power		-
Agency approvals		UL 508, CSA 22.2-142, FM Class1 Div.2, CE, cUL

(1) Open circuit detect can be disabled on these ranges.

Output module characteristics (continued)			140 ACO 020 00	140 AVO 020 00
Model			140 ACO 020 00	140 AVO 020 00
Number of channels			4	
Addressing requirements			4 out words	
Loop voltage		≡	12...30 V	–
Loop resistance			$R_{min}(1) = \frac{V_{Loop} - 30 \text{ Vdc}}{0.02A}$ $R_{min} = \frac{V_{Loop} - 7 \text{ Vdc}}{0.02A}$ No external resistor is required for loop voltage supply < ≡ 30 V (2)	* For a loop supply less than 30 volts, R_{min} is zero ohms.
Internal voltage drop		≡	7 V min., 30 V max. @ 20 mA	–
Voltage output ranges	Bipolar	≡	–	± 10 V (min. load resistance = 1 kΩ) (Jumper between reference - control terminals) ± 5 V (min. load resistance = 500 Ω) (Jumper between reference - control and output - R terminals)
	Unipolar	≡	–	0...10 V (min. load resistance = 1 kΩ) (Jumper between output - R terminals) 0...5 V (min. load resistance = 500 Ω) (Jumper between output - R and control - R terminals)
Output current			–	± 10 mA max any range (outputs are short circuit-proof)
Source resistance			–	0.1 Ω
Resolution			12 bits	
Accuracy error @ 25 °C			± 0.20% of full scale	± 0.15% of full scale
Linearity			±1 LSB	
Accuracy drift w/temperature	Typical		± 0.004% of full scale / °C	–
	Maximum		± 0.007% of full scale / °C	–
	Unipolar ranges		–	0.003% of full scale / °C typical 0.005% of full scale / °C max.
	Bipolar ranges		–	0.004% of full scale / °C typical 0.007% of full scale / °C max.
Isolation	Channel-to-channel		~ 500 V @ 47...63 Hz or ≡ 750 V for 1 minute	~ 500 V @ 47...63 Hz for 1 minute
	Channel-to-bus		~ 1780 V @ 47...63 Hz or ≡ 2500 V for 1 minute	~ 1780 V @ 47...63 Hz for 1 minute
Update time		ms	3 for all channels (simultaneous update)	3 for all channels
Setting time		μs	900 to ± 0.1% of the final value	700 to ± 0.1% of the final value (max.)
Fault detection			Open circuit in 4...20 mA mode. Specific channel is identified when an open circuit is detected through the red channel LED	–
Wire length		m	–	400 max.

(1) For a loop voltage supply < 30 V: $R_{MIN} = 0 \Omega$.
 (2) Up to 60 V with an external loop resistor.

Modicon Quantum automation platform

Analog I/O

Output module characteristics				
Model		140 ACO 020 00	140 AVO 020 00	140 ACO 130 00
Number of channels		See page 48205/7		8
Addressing requirements		Words	See page 48205/7	8 output
Module ranges and resolution		See page 48205/7		0...25 mA, 0...25,000 counts 0...20 mA, 0...20,000 counts 4...20 mA, 0...16,000 counts (default range) 4...20 mA, 0...4,095 counts
Loop voltage		V	See page 48205/7	6...30 max
Internal voltage drop		V	See page 48205/7	6 min, 30 max. @ 25 mA
Accuracy error @ 25 °C		See page 48205/7		± 0.2% of full scale
Linearity		See page 48205/7		± 4 µA 0...25 mA, 0...25,000 counts ± 4 µA 4...20 mA, 0...16,000 counts ± 12 µA 4...20 mA, 0...4,095 counts ± 4 µA 0...20 mA, 0...20,000 counts
Absolute drift w/temperature		See page 48205/7		Typical: 0.004% of full scale Maximum: 0.007% of full scale
Isolation	Channel-to-channel	See page 48205/7		None
	Field-to-bus	See page 48205/7		~ 1780 V for 1 minute
Update time		ms	See page 48205/7	5 for all 8 channels
Settling time full scale step change		ms	See page 48205/7	1.6 to 5% of the final value 3.2 to 0.1% of the final value
Fault detection		See page 48205/7		Open circuit in 4...20 mA mode. Specific channel is identified by the red channel LED. Also reported back to the controller in the I/O MAP status byte.
Bus current required		mA	480	700
Power dissipation		W	5.3 max.	4.5 max.
External power		See loop voltage on previous page		Not required for this module
Fusing	Internal	-		
	External	-		0.063 A, 250 V (1) Fuse type : 3 AG fast acting
Voltage Monitor	Range	1...5 V (main current loop must be active)		-
	Scaling	$V_{out} \text{ (Volts)} = I_{loop} \text{ (mA)} \times 0.25$		-
	Output impedance	Ω	300 typical	-
	Wire length	m	1 max	-
Agency approvals		UL 508, CSA 22.2-142, FM Class1 Div.2, CE, cUL		UL 508, CSA 22.2-142, FM Class1 Div.2, CE, cUL (pending)

(1) An internal fuse is required on the master override signal when it is connected to an external source.

Combo module characteristics				
Model		140 AMM 090 00		
Number of input channels		4 input/2 isolated output		
Addressing requirements		5 input words/2 output words		
Inputs operating ranges	Bipolar	± 10 V	± 5 V, ± 20 mA	–
	Unipolar	0...10 V	0...5 V, 0...20 mA	–
	Unipolar w/offset	–	–	1...5 V, 4...20 mA
Resolution		bits	16 in/12 out 16 for ± 10 V, 0...10 V. 15 for ± 5 V, 0...5 V, ± 20 mA, 0...20 mA. 14 for 1...5 V, 4...20 mA	
Voltage	Linear measuring range	2.4% over and under range		
	Absolute maximum	V	± 50	
	Impedance in range	MΩ	> 10	
	Impedance over range	W	> 0.5	
Current	linear measuring range	± 2.4% over range, and - 9.6% under range		
	Absolute maximum	mA	± 25	
	Impedance	Ω	250	
Absolute accuracy error @ 25° C (voltage mode)	Typical	± 0.03 %		
	Maximum	± 0.05% of full scale		
Linearity		Monotonic ± 1 LSB		
Offset	0...60 °C	%/°C	± 0.0014 of full scale max.	
Gain shift	0...60 °C	± 0.002 of full scale max.		
Common mode rejection		dB	> 80 @ 50 or 60 Hz	
Input filter		dB	- 3 @ 21 Hz (+ 20%), single-pole low-pass	
Operating voltage	Channel-to-channel	V	± 40 max.	
Isolation	Channel-to-bus	~ 500 V, 750 V, for 1 minute		
	Input channel-to-output channel	~ 500 V, 750 V, for 1 minute		
Update time	ms		320 for 4 channels	
Fault detection		Open circuit in 4...20 mA range, or over range, or under range in bipolar modes only.		

Combo module characteristics			
Model		140 AMM 090 00	
Outputs	Loop voltage	---	7...30 V; up to 60 V with an external resistor
	Loop resistance		$R_{min} = \frac{V_{Loop} - 30 \text{ Vdc}}{0.020 \text{ A}}$ $R_{min} = \frac{V_{Loop} - 7 \text{ Vdc}}{0.020 \text{ A}}$
Internal voltage drop		--- V	7 min, 30 max @ 20 mA
Resolution		bits	12
Accuracy error			± 0.20% of full scale @ 25°C
Linearity			Monotonic +1 LSB
Accuracy error 0...60 °C	Typical	%/°C	± 0.004 of full scale
	Maximum	%/°C	± 0.007 of full scale
Isolation	Channel-to-channel		~ 500 V, --- 750 V, for 1 minute
	Channel-to-bus		~ 500 V, --- 750 V, for 1 minute
	Output channel-to-input channel		~ 500 V, --- 750 V, for 1 minute
Update time		ms	15 for 2 channels
Settling time		µs	900 to ± 0.1% of the final value
Fault detection			Open circuit indicator light and status byte
External power			See loop voltage above
Voltmeter monitor	Range		1...5 V (main current loop must be active)
	Scaling		Iout (mA) x 0.250 = Vout (V)
	Output impedance	Ω	300 typical
	Max wire length	m	1
Common		words	5 in /2 out
Bus current required		mA	350
Fusing	Internal		-
	External		User discretion
Agency approvals			UL 508, CSA 22.2-142, FM Class1 Div.2, CÉ, cUL

(1) No R_{min} is required for loop voltage less than a 30 V.

Modicon Quantum automation platform

Analog I/O

Analog input modules

Description	Range	Reference	Weight kg (lb)
8 channels, 12-bit, single-pole	4 ... 20 mA or $\sim 1 \dots 5$ V	140 ACI 030 00	0.300 (0.66)
16 channels, 0...25,000 counts max.	0 ... 20 mA 0 ... 25 mA 4 ... 20 mA	140 ACI 040 00	0.300 (0.66)
8 channels, 13-bit, RTD	Ni or Pt 100, 200, 500, 1000	140 ARI 030 10	0.300 (0.66)
8 channels, 16-bit, thermocouple	Type J, K, E, T, S, R, B and mV	140 ATI 030 00	0.300 (0.66)
8 channels, 16-bit, two-pole	± 10 V, ± 5 V, 0...10 V, 0...5 V, 1...5 V, or ± 20 mA, 0...20 mA, 4...20 mA	140 AVI 030 00	0.300 (0.66)

Analog output modules

Description	Range	Reference	Weight kg (lb)
4 channels, 12-bit	4 ... 20 mA	140 ACO 020 00	0.300 (0.66)
8 channels, 0...25,000 counts	0 ... 20 mA 0 ... 25 mA 4 ... 20 mA	140 ACO 130 00	0.300 (0.66)
4 channels, 12-bit	± 5 V, ± 10 V 0...5 V, or 0...10 V	140 AVO 020 00	0.300 (0.66)

Analog I/O module

Description	Range	Reference	Weight kg (lb)
4 inputs, 2 outputs	± 5 V, ± 10 V, 0...5 V, 0...10 V, 1...5 V, or ± 20 mA, 4 ... 20 mA, 0...20 mA	140 AMM 090 00	0.900 (1.98)

Accessories

Description	Sold in lots of	Unit reference	Weight kg (lb)
Terminal block, 40 points required for all modules	–	140 XTS 002 00	0.150 (0.33)
Terminal block, 40 points (IP 20) for I/O analog modules	–	140 XTS 001 00	–
Coding kit for terminal block	60	140 XCP 200 00	–
Analog I/O simulator, one 0...5 V meter and two 10-turn potentiometers for 140 A●I 030 00 input modules, 140 A●O 020 00 output modules, 140 AMM 090 00 I/O modules	–	140 XSM 010 00	–

Wiring diagrams

140 ACI 030 00

140 ACO 020 00

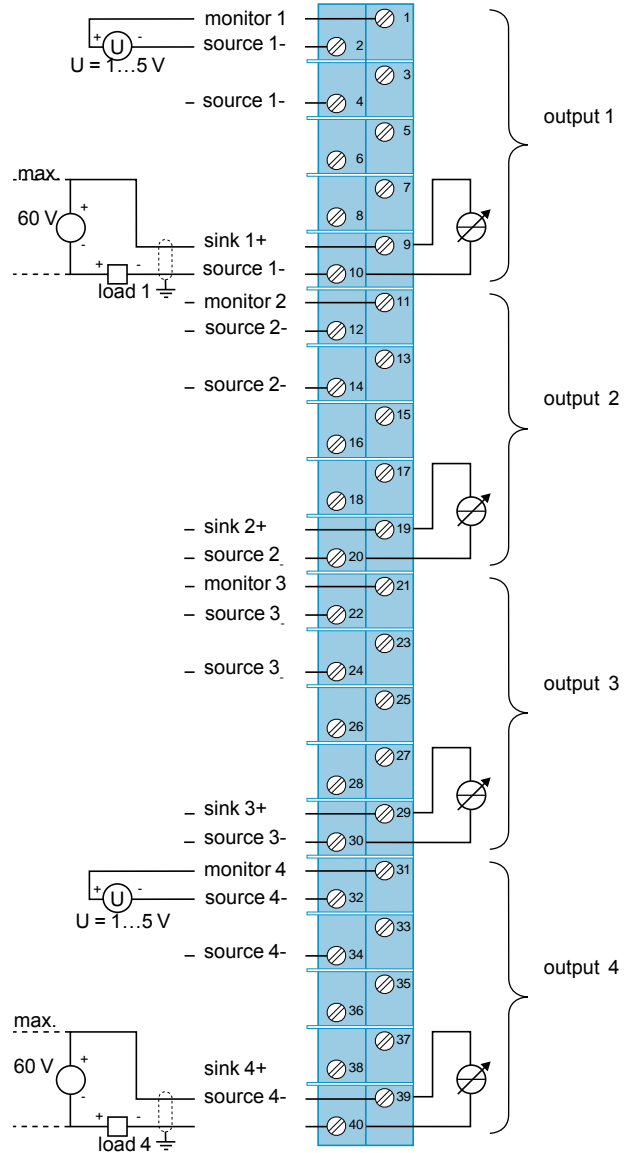
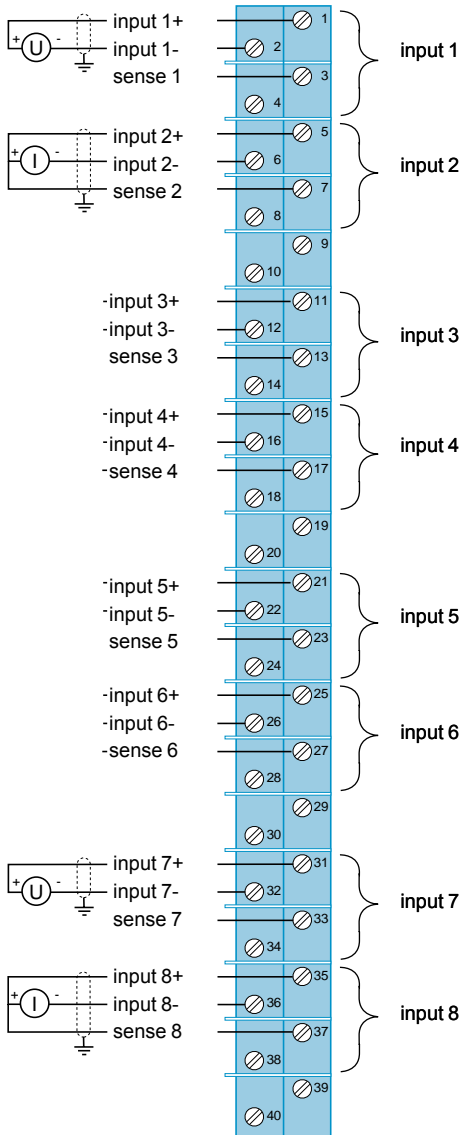

Wiring diagrams

140 AVI 030 00

140 AVO 020 00

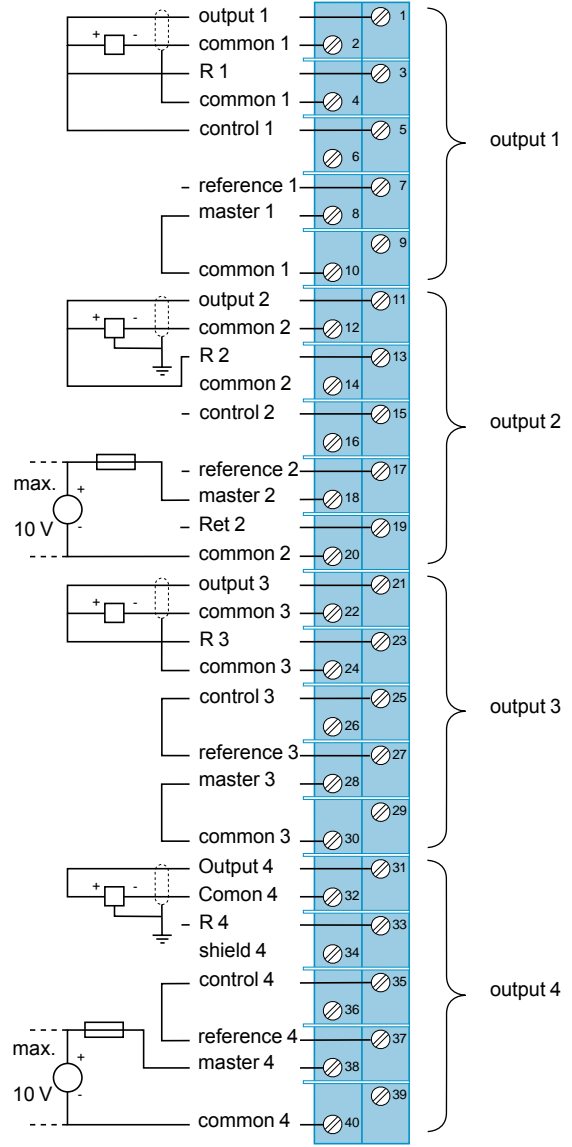
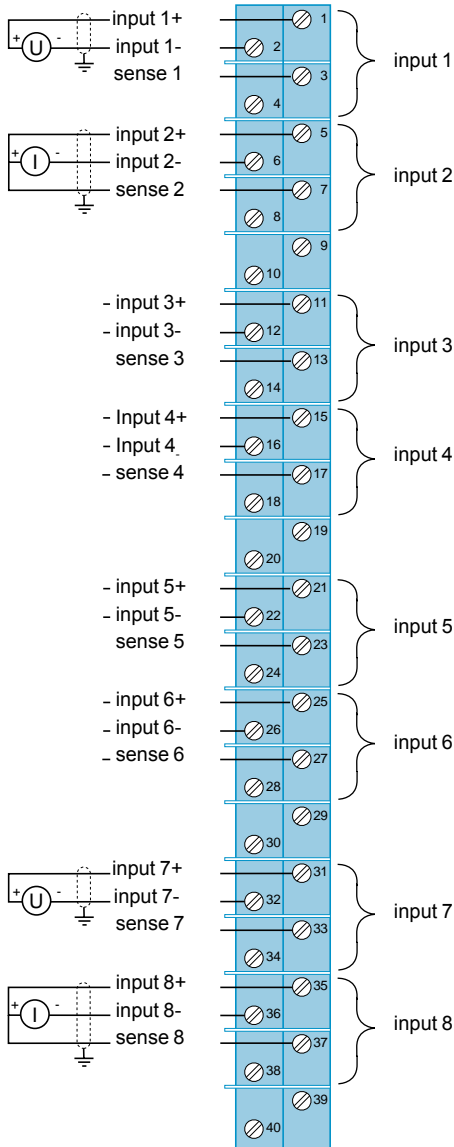

The various wiring options are:
 channel 1 for 0...+ 5 V d.c.,
 channel 2 for 0...+ 10 V d.c.,
 channel 3 for - 5...+ 5 V d.c.,
 channel 4 for - 10...+10 V d.c.

Wiring diagrams

140 AMM 090 00

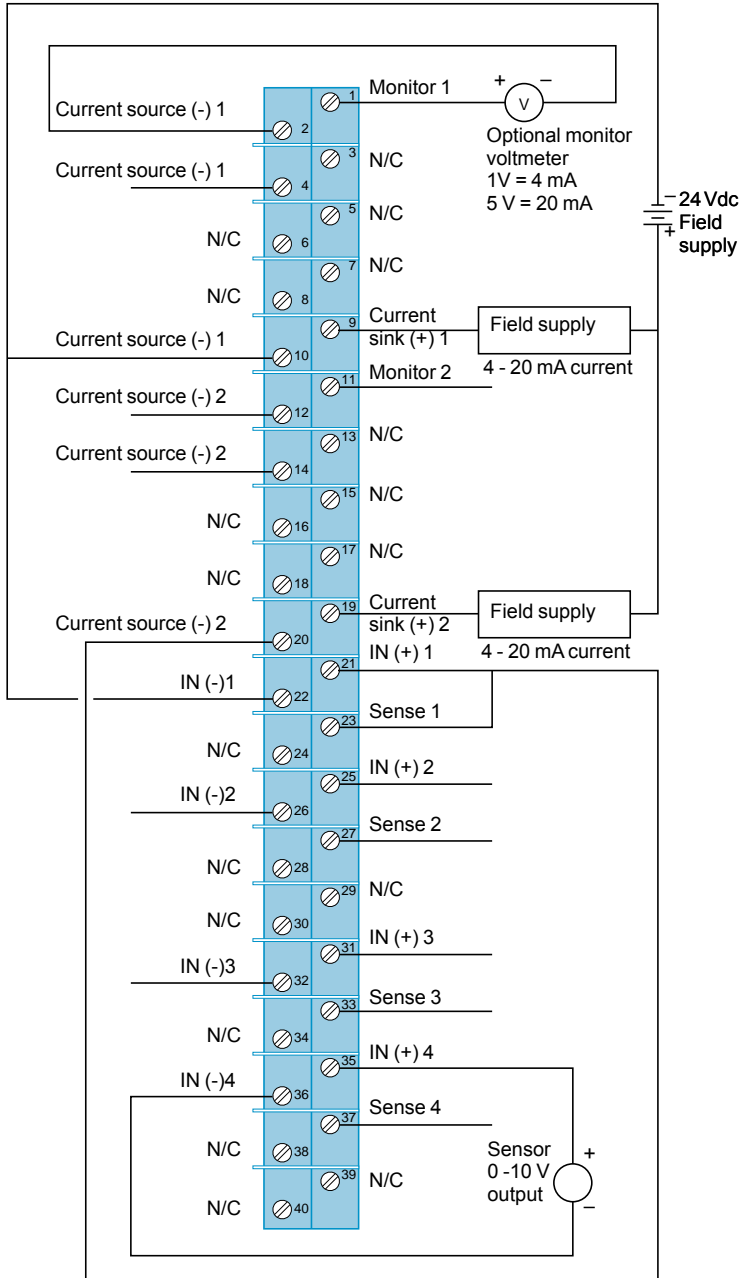

Output Section 2 Channels Typical Wiring Outputs

Channel 1 - The output shows a connection to an external field device and optional monitor.

Channel 2 - The output shows a connection to an external field device and the input of channel 1.

Input Section 4 Channels Typical Wiring Inputs

Channel 1 - Channel 1 shows 4 - 20 mA current input controlled by output section channel 2.

Channel 4 - The input shows a connection to a voltage output sensor.

- Pins 1...20 are outputs
- Pins 21...40 are inputs
- N / C = Not Connected
- Jumpers are required between IN (+) and SENSE terminals for all current input ranges.

Wiring diagrams

140 ARI 030 10

140 ATI 030 00

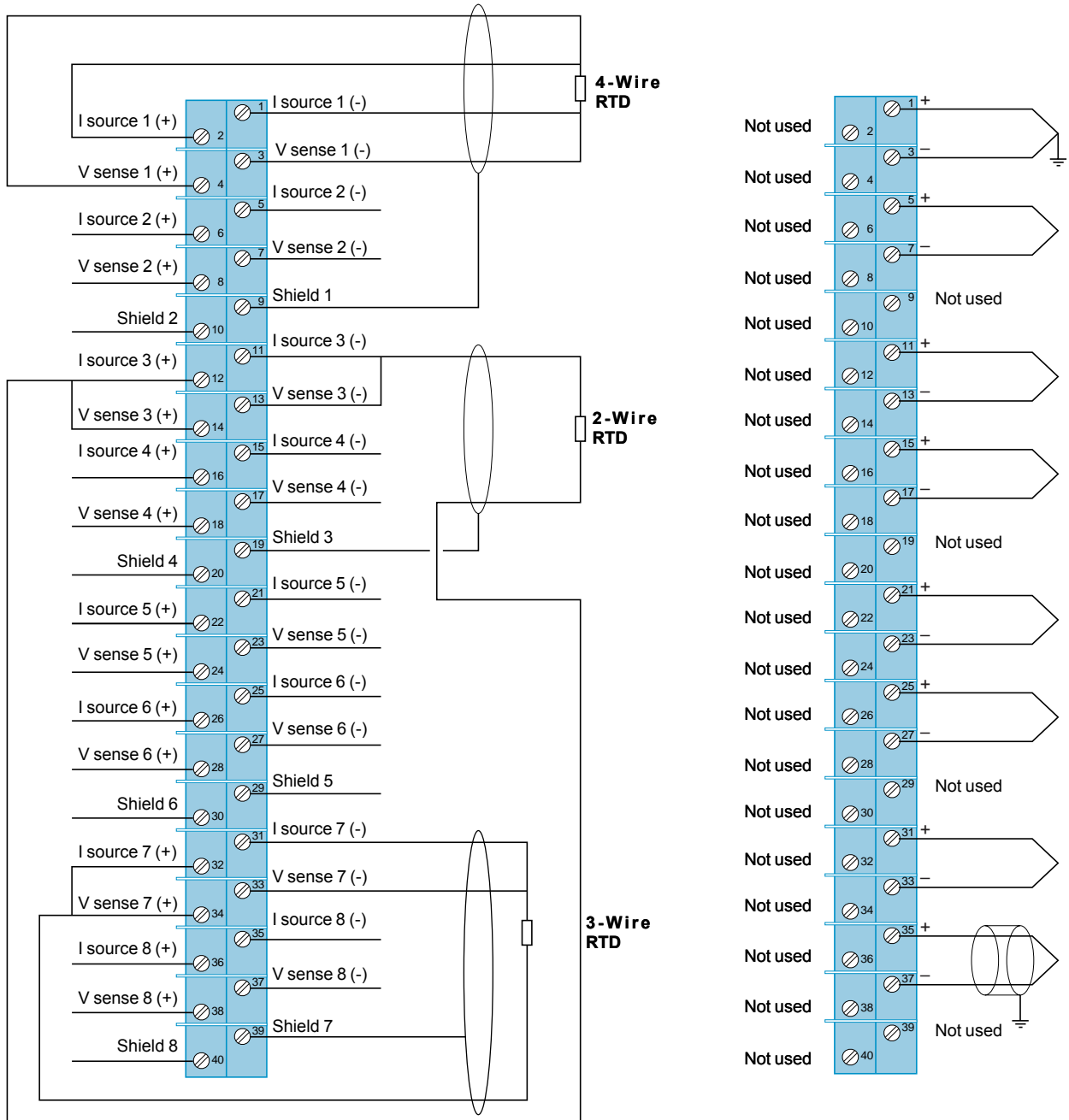

- The module is calibrated per:
IEC Publication 751 for platinum RTDs: $100 \Omega @ 0^\circ\text{C}$, $\text{TCR}(a) = 0.00385\Omega/\Omega/^\circ\text{C}$
DIN 43760 for nickel RTDs
American Platinum RTDs:
 $100 \Omega @ 0^\circ\text{C}$, $\text{TCR}(a) = 0.00392\Omega/\Omega/^\circ\text{C}$

■ Terminals labeled shield are not connected internally; shields should be grounded at the field device end.

■ When using 2-wire configurations, the temperature equivalent of twice the lead resistance of one leg must be subtracted from the temperature reading.

■ Either shielded or unshielded TCs may be used. (The user should consider using shielded wire in a noisy environment.) Shielded types should have a shield tied to earth ground near the signal source end.

■ Connections marked **Not used** are not electrically connected within the module. These points are used as a thermal link to ambient air. They are not recommended as electrical tie points as this could affect the accuracy of cold junction compensation.

Wiring diagrams

140 ACI 040 00

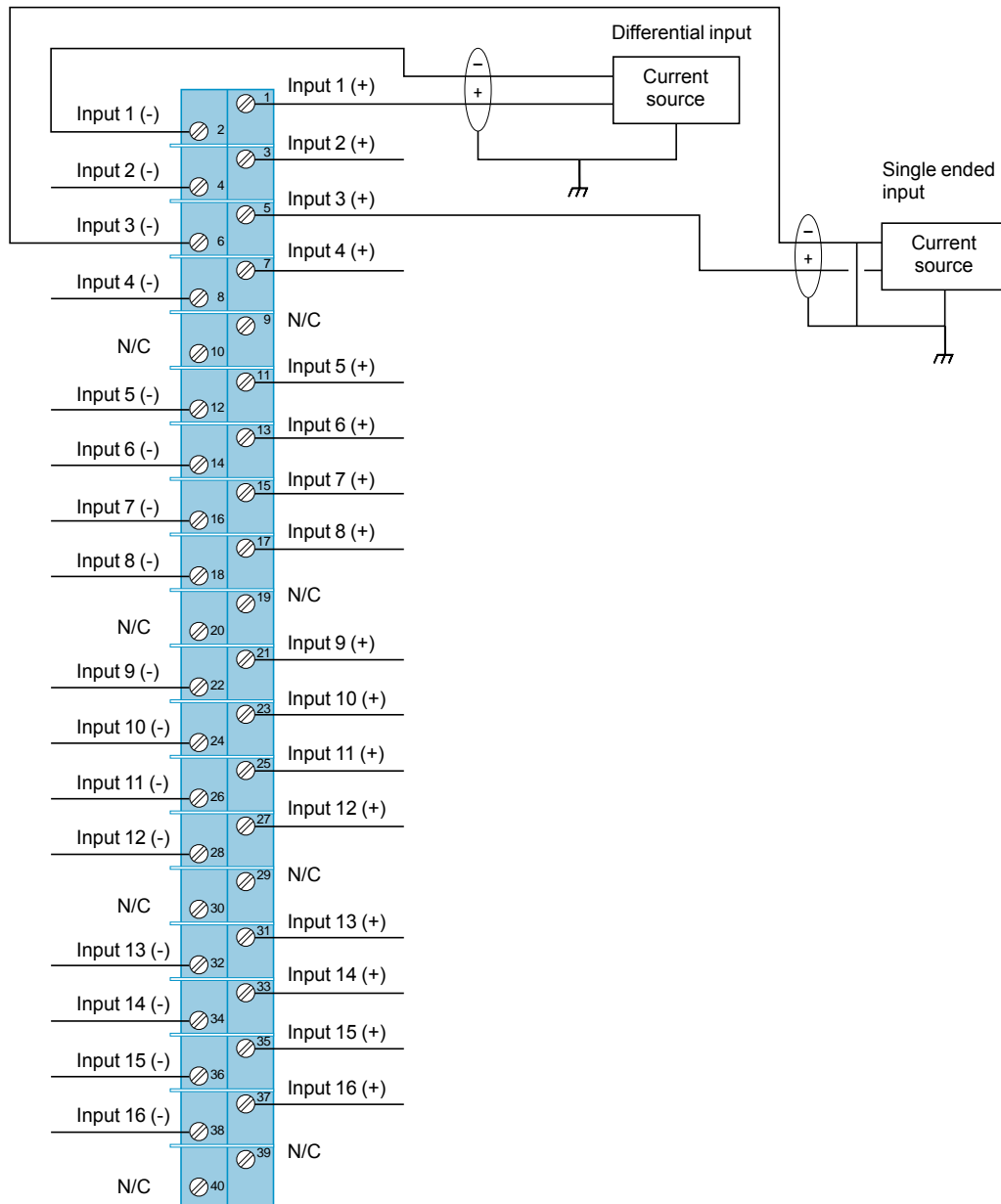

■ Either shielded or unshielded signal cables may be used. In noisy environments, twisted shielded cable is recommended. Shielded cable should have a shield tied to earth ground near the signal source end.

■ Unused inputs may cause the activation of the F LED. To avoid this occurrence, the unused channels should be configured in the 0 to 25 mA range.

■ The maximum channel-to-channel working voltage cannot exceed \approx 30 V.

N/C = Not Connected

Wiring diagrams

140 ACO 130 00

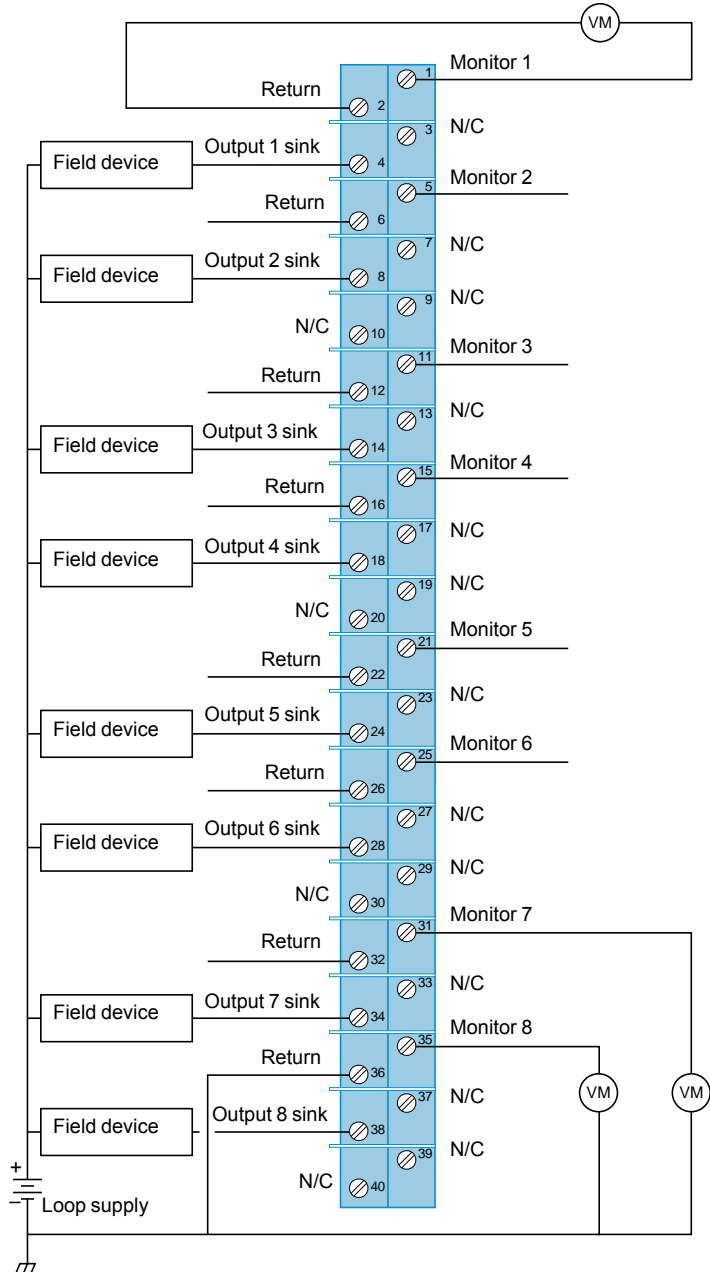

- VM is an optional voltmeter that can be connected to read voltage that is proportional to the current. Wiring to this terminal is limited to 1 meter maximum.
- Either shielded or unshielded signal cables may be used. In noisy environments, twisted shielded cable is recommended. Shielded cable should have a shield tied to earth ground near the signal source end.
- Unused outputs may cause the activation of the F (fault) LED. To avoid this occurrence, it is recommended that the unused channels be configured in the 0 to 25 mA range.
- All terminals labeled "Return" are common inside the module.
- N / C = Not Connected.
- At power up, the channel outputs are all at 0 (zero) current.